

CDG-500 Capacitance Diaphragm Gauge

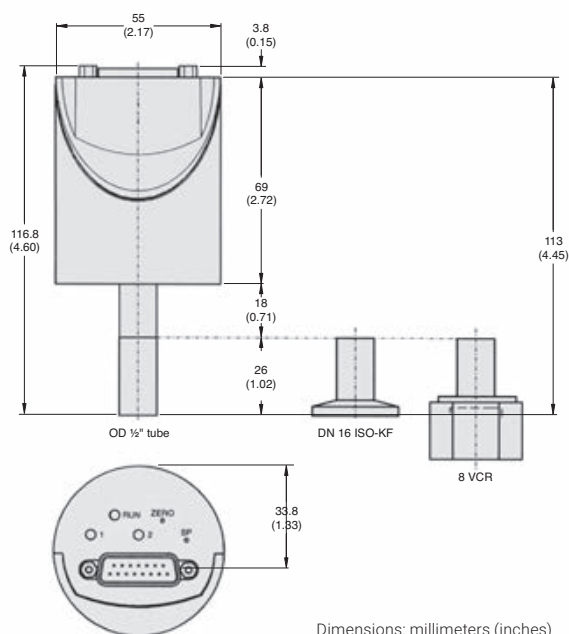

The Agilent CDG-500 series of temperature compensated capacitance diaphragm gauges provides the highest level of accuracy in the high-pressure region. Full-scale measurement ranges are available from 1000 to 1 Torr (1333 to 1.3 mbar).

The CDG-500 series uses a corrosion resistant ultra pure alumina ceramic diaphragm providing exceptional signal stability, fast recovery from atmosphere, short warmup times, and unparalleled robustness.

Used in a variety of applications such as thin film and vacuum processes, industrial vacuum processes, data storage, and semiconductor production processes.

Features	Benefits
Full scale ranges from 1 to 1000 Torr with push button zeroing and optional set point control	Ease of integration
Excellent long term signal stability and repeatability	Long term performance – comparable to competitor's heated versions
Fast recovery from atmospheric pressures and rapid stabilization after start-up	Reduces process cycle times
Corrosion resistant ceramic sensor with sensor shielding protection	Application robustness

Technical Specifications

Measurement range (full scale)	Torr	1 - 1000 Torr	0.1 - 100 Torr	0.01 - 10 Torr	0.001 - 1 Torr
	Pa	133 - 133,322 Pa	13.3 - 13,332 Pa	1.33 - 1,333 Pa	0.133 - 133 Pa
	mbar	1.33 - 1333 mbar	0.133 - 133 mbar	1.33 x 10 ⁻² - 13.3 mbar	1.33 x 10 ⁻³ - 1.33 mbar
Accuracy ¹	% of reading	0.2	0.2	0.2	0.2
Temperature effect on zero	% F.S./°C	0.005	0.005	0.005	0.015
	% of reading/°C	0.01	0.01	0.01	0.01
Resolution	% F.S.	0.003	0.003	0.003	0.003
Pressure, maximum	kPa (absolute)	400	260	260	260
Lowest reading	% F.S.	0.01			
Lowest suggested reading	% F.S.	0.05			
Lowest suggested control pressure	% F.S.	0.05			
Temperature	Operation (ambient) 5 to 50 °C	Bakeout (at flange) ² ≤ 110 °C		Storage -40 to 65 °C	
Supply voltage	14 to 30 VDC				
Power consumption	≤ 1 W				
Output signal (analog)	0 to 10 VDC				
Response time	30 ms				
Degree of protection	IP30				
Electrical connection	D-sub, 15 pole, male				
Setpoints ³ – Two (2) setpoints, SP 1 and SP 2	Relay Contact 30 VDC; ≤ 0.5 ADC		Hysteresis 1% of F.S.		
Materials exposed to vacuum	Aluminum oxide ceramic (Al ₂ O ₃), Vacon 70 ⁴ , stainless steel (AISI 316L ⁵) AgCuTi hard solder, sealing glass				

¹ Non-linearity, hysteresis, repeatability at 25 °C ambient operating temperature without temperature effects after 2 hours operation

² Non operating

³ CDG-500 setpoint versions only

⁴ 28% Ni, 23% Co, 49% Fe

⁵ 18% Cr, 10% Ni, 3% Mo, 69% Fe

Ordering Information

Description	Part Number	
	KF16	VCR8
CDG-500 Capacitance Diaphragm Gauge (1000 Torr)	CDG500T1000KF16	CDG500T1000VCR8
CDG-500 Capacitance Diaphragm Gauge (100 Torr)	CDG500T0100KF16	CDG500T0100VCR8
CDG-500 Capacitance Diaphragm Gauge (10 Torr)	CDG500T0010KF16	CDG500T0010VCR8
CDG-500 Capacitance Diaphragm Gauge (1 Torr)	CDG500T0001KF16	CDG500T0001VCR8
CDG-500 Capacitance Diaphragm Gauge (1000 Torr) with setpoints	CDG500T1000KF16S	CDG500T1000VCR8S
CDG-500 Capacitance Diaphragm Gauge (100 Torr) with setpoints	CDG500T0100KF16S	CDG500T0100VCR8S
CDG-500 Capacitance Diaphragm Gauge (10 Torr) with setpoints	CDG500T0010KF16S	CDG500T0010VCR8S
CDG-500 Capacitance Diaphragm Gauge (1 Torr) with setpoints	CDG500T0001KF16S	CDG500T0001VCR8S

Contact information

Americas

Agilent Technologies
121 Hartwell Avenue,
Lexington, MA 02421 USA
Toll free: +1 800 882 7426
vpl-customer@agilent.com

Europe, Middle East, Africa, India

Agilent Technologies Italia SpA
Via F.lli Varian 54,
10040 Leini (Torino), Italy
Tel: +39 011 9979 111
Toll free: 00 800 234 234 00
vpt-customer@agilent.com

China

Beijing Office Agilent Technologies (China) Co. Ltd.
No.3, Wang Jing Bei Lu,
Chao Yang District,
Beijing, 100102, China
Toll free: 800 820 6778
Contacts.vacuum@agilent.com

For more information, please contact
your Agilent representative or visit
www.agilent.com/chem/vacuum where
you can chat live with a vacuum expert.



[https://www.agilent.com/en/product/
vacuum-technologies/vacuum-measurement
/active-gauges/cdg-500-capacitance-diaphragm-gauge](https://www.agilent.com/en/product/vacuum-technologies/vacuum-measurement/active-gauges/cdg-500-capacitance-diaphragm-gauge)

DE44449.4941087963

This information is subject to change without notice.

© Agilent Technologies, Inc. 2021
Printed in the USA, September 21, 2021
5994-4121EN