

Technical description

C2/340/40/3



Illustration is similar (contains additional equipment)

Contents

Highlights	3
Testing standards.....	4
Performance data	5
Technical data.....	7
Our basic equipment	10
Your additional equipment.....	13

Highlights

- **Visual status bar**
The operating status always in view: Boot process, ready for use, test progress and messages.
- **Homogeneous LED test space lighting**
Optimal lighting conditions in the test room - even with the door open.
- **Smart privacy screen (optional)**
To ensure that secrets remain secret, the test space becomes opaque at the push of a button.
- **Flexible test space**
Quick integration of test equipment with a rail system and mounting threads.
- **Integrated web panel**
Foldable, 25.4 cm (10") touch display with **WEBSeason®** remote control software.
- **Precise absolute humidity control**
Highest control accuracy for climate change tests and high temperature / humidity combinations.
- **Intelligent water management**
The digital fill level and consumption display makes the filling of demineralised water plannable.
- **Ergonomic door handle**
Easy operation with three intuitive positions: closed, open, ventilate.
- **Extra-large water bath**
For increased humidification and dehumidification performance, to meet the most demanding test standards
- **Practical storage and accessories package (optional)**
The multifunctional storage system simplifies organization and ensures a tidy testing environment.



Illustration is similar (contains additional equipment)

Into the age of connectivity – with **WEBSeason®**



You can use the innovative user interface **WEBSeason** to program, control and monitor your tests at any time and anywhere, even from your tablet or smartphone. Settings, language and units can be set and saved to suit the individual user. **WEBSeason** provides a new dimension of flexibility and efficiency.

Simple operation for optimal processes



With a new design, practice-oriented menu navigation and high-performance evaluation, the new version of the proven **SIMPATI®** control software not only offers operating efficiency and performance, but a platform-based extension for the automatic generation of test reports with **SIMPATI** online. Up to 99 test chambers can be integrated and linked for this purpose.

Testing standards

Low-temperature tests

IEC 60068-2-1, Test A
ISO 16750-4, Low temperature
ETSI EN 300019-2-4, Test Ab/Ad
MIL-STD-810 G, Meth. 502.5
JESD22-A119

High-temperature tests

IEC 60068-2-2, Test B
ISO 16750-4, High-temperature test
ETSI EN 300019-2-4, Test Bb/Bd
MIL-STD-202 G, Meth. 108A
MIL-STD-810 G, Meth. 501.5
MIL-STD-883 J, Meth. 1008.2
JESD22-A103D

Alternating temperature tests

IEC 60068-2-14, Test Nb
ISO 16750-4, Temp. steps
ISO 16750-4, Temp. cycling
ETSI EN 300019-2-4, Test Nb
MIL-STD-331 C, Test C6

Constant climates

IEC 60068-2-67
IEC 60068-2-78
ISO 16750-4, Damp heat steady
ETSI EN 300019-2-4, Test Cab
MIL-STD-202 G, Meth. 103B
JESD22-A101C

Alternating climates

IEC 60068-2-30, Test Db, Var. 1
IEC 60068-2-30, Test Db, Var. 2
IEC 60068-2-38
ISO 16750-4, Damp heat cyclic
ISO 16750-4, Temp/Humid, cyclic
ETSI EN 300019-2-4, Test Db
VG 95210, Blatt 7, Meth. 106C
MIL-STD-202 G, Meth. 106D
MIL-STD-331 C, Test C1
MIL-STD-750-1, Change 3
MIL-STD-810 G, Meth. 507.5
MIL-STD-883 J, Meth. 1004.7
JESD22-A100D

The temperature values specified in the standards (severity levels) are limited by the highest and lowest test space temperature. The choice of the appropriate test system depends on the temperature change rates during alternating tests. The requirements are met if the test system capacity is large enough to compensate for the influence of the specimen and its heat dissipation in the relevant capacity range. Please contact us to test the feasibility with your test specimen.

The reference point for test values and tolerance specifications is the middle of the test space (without measurement uncertainty). Verifying documentation for individual test values is optionally available at additional cost.

Your standard is not listed? Contact us!

Performance data

Performance data for temperature tests¹

Maximum temperature	+180 °C
Minimum temperature ²	-42 °C
Rate of temperature change ³ , cooling	4.0 K/min
Rate of temperature change ³ , heating	3.2 K/min
Temperature deviation ⁴ , in time	±0.1 K to ±0.5 K
Temperature homogeneity ⁵ , in space	±0.5 K to ±1.0 K
Temperature gradient ⁶	≤2,0 K
Heat compensation ⁷ , max.	2300 W
Factory calibration values ⁸	+80 °C and -25 °C

Performance data for climate tests

Maximum temperature	+95 °C
Minimum temperature	+10 °C
Temperature deviation ⁴ , in time	±0.1 K to ±0.3 K
Temperature homogeneity ⁵ , in space	±0.5 K to ±1.0 K
Dew point temperature range ⁹	-3.0 °C to +94.0 °C
Humidity range	10 % RH to 98 % RH
Humidity deviation ¹⁰ , in time	±1 % RH to ±3 % RH
Humidification water consumption ¹¹ , for every 24 h	2 l
Heat compensation ¹² , max.	400 W
Factory calibration values ⁷	+90 °C/90 % RH; +55 °C/93 % RH; +23 °C/50 % RH

¹ The performance data refers to +25 °C ambient temperature and +18 °C cooling water temperature, 400 V/50 Hz nominal voltage, without specimen, without additional equipment and without heat compensation. The test chamber is designed for installation inside dry and ventilated spaces with max. degree of contamination "2" according to EN 50178:1997. The permissible ambient temperature during operation is between +10 °C and +35 °C. The max. permissible relative humidity must not exceed 75% RH and the max. dew point must not exceed +20 °C.

² Temperatures >+5 °C are permitted in continuous operation; temperatures <+5 °C are permitted discontinuously or with the additional equipment "compressed air dryer".

³ According to IEC 60068-3-5; average, measured in the supply air / According to IEC 60068-3-6, average, measured in the supply air for climate tests.

⁴ In the middle of the test space when it is empty and at steady state, without specimen, without heat radiation and without additional equipment, depending on temperature.

⁵ Relative to the selected set point in the temperature range from the minimum temperature up to +150 °C and/or at humidity >20% RH (without measurement uncertainty).

⁶ Up to +150 °C according to IEC 60068-3-5:2001 and/or JF 1101-2003.

⁷ At +20 °C for temperature tests.

⁸ The factory calibration of the temperature / climate values is carried out with DAkkS-calibrated measuring equipment in the middle of the test space and documented with a certificate. A DAkkS calibration, as well as a spatial factory or a spatial DAkkS calibration, can be provided on request.

⁹ Discontinuous operation (-3.0 °C to +4.0 °C).

¹⁰ In the middle of the test space when it is empty and at steady state, without specimen, without heat radiation and without additional equipment, depending on climate value.

¹¹ At +40 °C and 92% RH.

¹² In the range from +25 °C to +95 °C at a relative humidity up to 90% RH for climate tests

Performance data

Climate chart

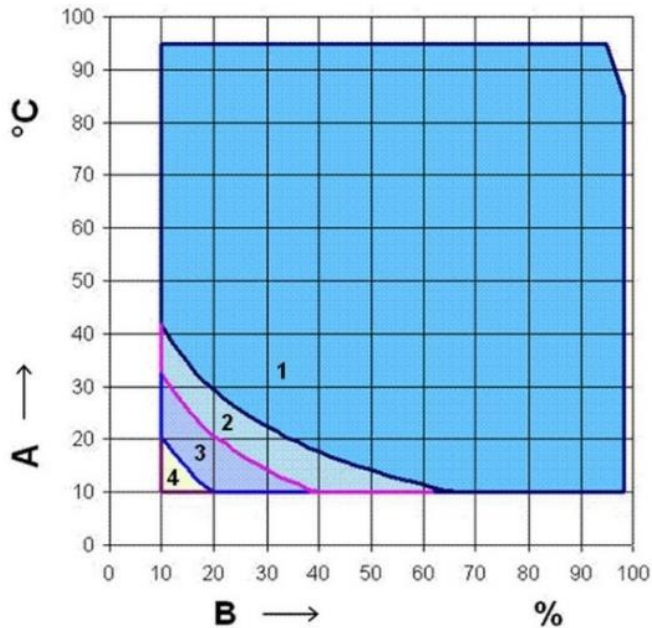

A Test space temperature in °C

B Relative humidity in % RH

- 1 Standard climate range for continuous operation
- 2 Standard climate range for discontinuous operation only (dew point temperature range from +4.0 °C to -3.0 °C)
- 3 Extended climate range with dew point temperatures controlled up to -12 °C using dried compressed air (optional)
- 4 Extended climate range with dew point temperatures controlled up to -20 °C using dried compressed air and capacitive humidity measuring system (optional)

Technical data

Technical data

Test space volume	332 l
Test space dimension (H x W x D)	750 mm x 580 mm x 765 mm
Useable width	540 mm
Exterior housing dimensions (H x W x D)	1830 mm x 900 mm x 1890 mm
Minimum exterior housing dimensions ¹³ (H x W x D)	1725 mm x 800 mm x 1715 mm
Total load of multiple insertion shelves and test space floor ¹⁴	140 kg
Load of the test space floor ¹⁴	60 kg
Load per insertion shelf ¹⁴	30 kg
Total load for multiple insertion shelves ¹⁴	80 kg
Total weight without loading and additional equipment	490 kg
Voltage rating ¹⁵	3/N/PE AC 400 V ±10 % 50 Hz
Power rating, max. ¹⁶	4.4 kW
Current rating ¹⁷	13 A
Connector	CEE Plug, 16 A
Connection cable	3.5 m
Fuse protection ¹⁸	16 A gG
Protection class of switchgear cabinet and control unit ¹⁹	IP 54
Sound pressure level ²⁰	56 dB(A)
Heat dissipation to the installation room, maximum	3.7 kW

¹³ For transport and move-in. Parts can be removed at additional expenses.

¹⁴ Max. load as surface load.

¹⁵ The test chamber can also be operated at 3/N/PE AC 380 V ±10 % 50 Hz. In this case, the heating rate is reduced by approximately 10%.

¹⁶ The power rating quoted for **weisstechnik** products describes the maximum power consumption during operation at full load. As this state only occurs in rare cases, conclusions about energy consumption cannot be drawn from the power rating quoted.

¹⁷ Neutral conductor under load.

¹⁸ Provided by the customer.

¹⁹ EMC tests and information about emitted interference according to EN 61000-6-3:2007 / EN 61000-6-4:2020. Interference immunity is in accordance with EN 61000-6-2:2019.

²⁰ Measured at a distance of 1 m from the front of the test chamber and a height of 1.6 m in free-field measurement according to EN ISO 11201:2010.

Technical data

Connections

The Test Chamber is delivered ready for connection.

The supply and disposal connections are located on the rear side at the bottom, approx. 170 mm above floor level.

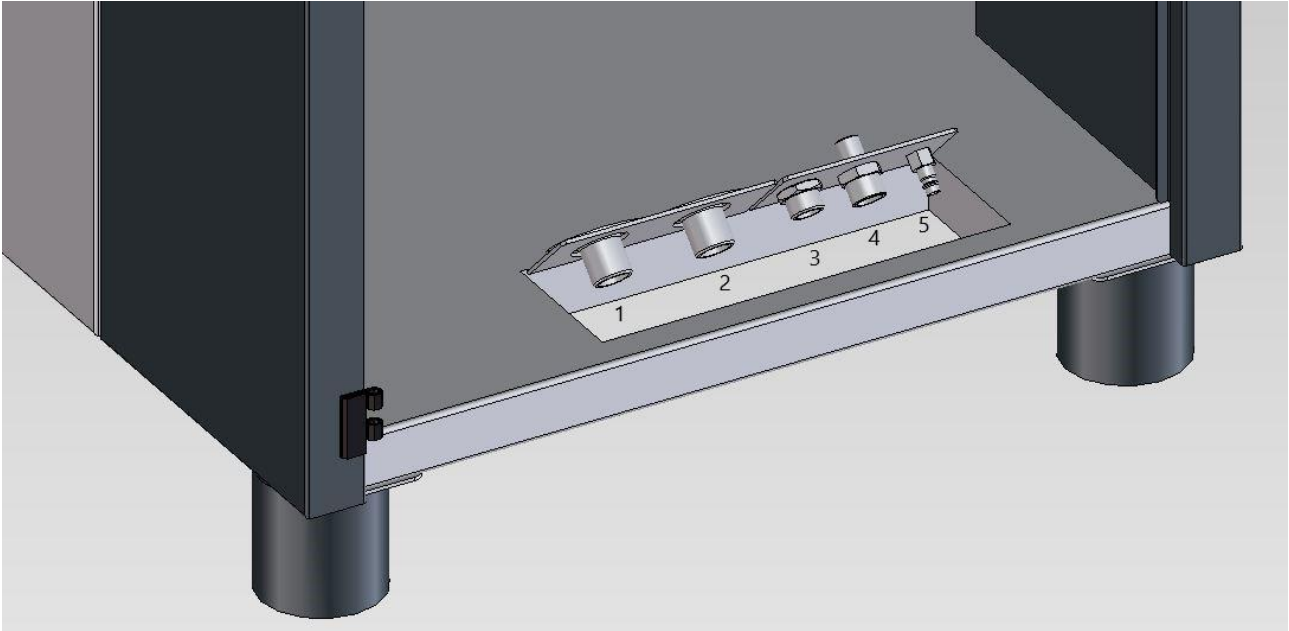

The following connections are illustrated above:

- 1 Cooling water inlet²¹, Rp 3/4" female thread
- 2 Cooling water outlet²¹, Rp 3/4" female thread
- 3 Overflow/condensate drain backpressure-free, G 3/4" male thread resp. hose connection \varnothing 12 mm
- 4 Demineralized water supply, R 3/4"
- 5 GN₂/Compressed air, DN 7.2, max. 10 bar (optional)

²¹ Optional for 3 K test chamber

Technical data

Installation drawing

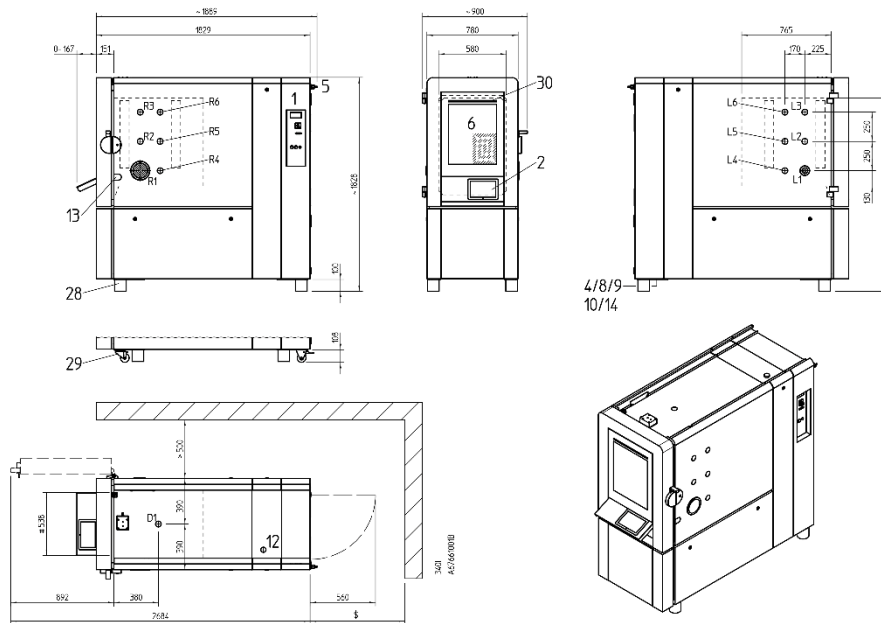

“Mobile version” (option): The height varies depending on the model; the exact values are stated in the option description and installation drawing.

§: min. 200 mm, a wall clearance of at least 700 mm is required for service work (acc. to IEC 60364-729 (VDE 100 part 729)).

Access ports

- R1 Ø 125 mm (installed in basic equipment)
- L1 Ø 50 mm (installed in basic equipment)
- R2-R6 Additional installation positions right (option)
- L2-L6 Additional installation positions left (option)
- D1 Additional installation position ceiling (option)

Equipment

- 1 Main switch
- 2 **WEBS**Season® control unit 25.4 cm (10") touch display
- 4 Connection for overflow and condensate drain
- 5 Electrical connection
- 6 Test space door with window (option)
- 8 Cooling water supply²²
- 9 Cooling water return²²

Additional information

- ~ Transport dimensions
- # Width between shelves
- § Escape route acc. to IEC 60364-7-729 (VDE 100 part 729)
- 10 Connection for demineralized water
- 12 Pressure compensation opening
- 13 Notch port or flat notch port (option)
- 14 Compressed-air connection/GN₂ (option)
- 28 Adjustable, vibration absorbing feet
- 29 Mobile design (option)
- 30 LED status bar

²² Optional for 3 K test chamber

Our basic equipment

Exterior

Exterior housing

Material	Double-coated galvanized steel sheet
Finish	RAL 7035 light grey, design elements in RAL 7016 anthracite, solvent-free, powder coated
Door	Hinged on the left side, lockable, one-handed operation with LED status bar
Feet	Adjustable, vibration-absorbing

Refrigeration unit²³

Type	air-cooled				
Refrigerant ²⁴	Stage	Refrigerant	GWP	Fill quantity	CO ₂ -equivalent
	Pre-cooling	R449A	1397	2.5 kg	3.5 t

Cooling water²⁵

Connection data	Water pressure 2.5 to 6 bar, differential pressure ≥ 2 bar, Water temperature +12 °C to +28 °C
Consumption	Max. 0.5 m ³ /h at Δt 10 K at +18 °C; Max. 1.1 m ³ /h at Δt 5 K at +28 °C
Quality ²⁶	No pollutants (max. particle size <100 μ m, ph value approx. 7.0 to 9.0),
Power to be discharged	Max. 3.1 kW

Humidification system

Humidification water	Water reservoir (approx. 25 l), pre-installed equipment for automatic water supply with warning in the event of water shortage
Humidification water quality	pH value 6.0 to 7.0, demineralised, conductivity 5 to 20 μ s/cm
Purge device	The high quality of the humidification water is guaranteed by periodic water exchange

²³ The product contains fluorinated greenhouse gases.

²⁴ (EU) directive no. 517/2014 specifies an obligation for stationary refrigeration and air conditioning units with a CO₂ equivalent of 5 to 50 t to be checked for leaks at least annually and an equipment logbook to be kept; by installing an automatic leak detection system, the interval for the leak test can be doubled. We can carry out these tasks for you in our capacity as an expert partner. We would be glad to advise you on installing a leak detection system.

²⁵ Optional for 3 K test chamber.

²⁶ For operation with well, pond or river water special measures must be taken.

Our basic equipment

Interior

Test space²⁷

Test space illumination	The LED lighting (12 W) integrated into the test space illuminates the chamber evenly from above and facilitates to bring in and prepare the test specimen setup. The lighting can be switched on and off via the WEBS Season® control software
Floor material	Stainless steel 1.4404, surface II B matt
Wall material	Shelf layers stamped on the side, vertical spacing ²⁸ 60 mm Stainless steel 1.4301, surface III D polished
Insertion system	Rail system allowing shelf positions to be easily changed, 10 positioning options in vertical spacing
Insertion shelf	1 pc., stainless steel, max. number of insertion shelves: 5
Equipment access port right side ²⁹	1 pc., approx. 125 mm Ø stainless steel, incl. closed silicone plug and slotted silicone plug
Equipment access port left side ²⁹	1 pc., approx. 50 mm Ø stainless steel, incl. closed silicone plug and slotted silicone plug

Measurement sensors

Temperature	Pt 100 platinum temperature sensor
Climate	Psychrometric humidity measurement with automatically wetted wet bulb temperature sensor Pt 100

Condensation protection

Dehumidifier	Can be switched on to avoid condensation on test specimen. This is achieved via separate dehumidifying coil.
--------------	--

²⁷ The use of tempered silicone parts means that the test space produces only low emissions. If the test space has to be emissions-free, this requires technical clarification; please contact us to request an offer.

²⁸ Tests must be set up at least 20 mm away from walls.

²⁹ Production-related tolerances of up to ±3 mm are possible.

Our basic equipment

Regulation and control

S!MPAC®

Digital measuring and control system with I/O unit and **WEBS**Season® software, remote controllable through integration into network

Operating/programming and monitoring unit within the door integrated 25.4 cm (10") touch display, fold-out up to 60° to the front.

Communication

Interfaces

4 digital outputs for control of customer-provided devices by means of potential-free contacts, max. load 24 V DC, 0.5 A

4 digital inputs for feedback of customer provided devices, max. load 24 V DC, 30 mA

1 Ethernet interface (100/1000 megabits) for integration in a network

1 USB interface for recording of measuring data on a flash drive³⁰

Customer protocols

SimServ (to control the test chamber via the Ethernet interface)

Safety

Test specimen protection

Independent adjustable temperature limiter t_{\min} / t_{\max} , separate sensor installed in the test space.

Software temperature limiter t_{\min} / t_{\max} , individually adjustable fixed value

Test chamber protection

Temperature limiter for protection against overtemperature in the test chamber

Specimen switch-off

Potential-free contact specifically for test specimens that emit heat, on female connector, max. load 24 V, 0.5 A

³⁰ Flash drive is not included in the scope of delivery. Before recording data, check that the flash drive is working.

Your additional equipment