



MMM Group

FRIOCELL[®] EVO

Incubator with Forced Air Circulation
and Active Cooling

NEW



Innovative Heat Technology



protecting human health

Tradition, Quality, Innovation

Since its establishment in 1921, BMT Medical Technology s.r.o., the traditional manufacturer of medical and laboratory technology, has been gradually transformed from a small regional company to an international corporation.

In 1992, it became a member of the European MMM Group which has been operating on the world markets since 1954 as an important supplier of systems for the health care industry, science and research. With its comprehensive offer of products and services, sterilization and disinfection devices for hospitals, scientific institutes, laboratories and pharmaceutical industry, MMM Group has established itself as an outstanding quality and innovations producer on the global markets.

The knowledge and experience gained during the implementations of individual supplies for our customers all over the world, and the technical innovations have been permanently and positively influencing the development, construction and production of our devices. High level of our work has also been confirmed by the number of patents and industrial designs as well as an easy implementation of individual device adjustments.

MMM Group - excellence in medical and laboratory technology.

Basic Characteristics

Volume: 55, 111, 222, 404, 707, 1212 l
Working temperature:
0.0°C up to 100°C
(options of -20°C and +160°C
decontamination)
Refrigerant:
R404a (down to -20°C),
R134a (down to 0°C)
Inner glass door
Interior: stainless steel,
mat. No. 1.4301 (AISI 304)

FRIOCELL® EVO

Precise and Energy-Saving Incubator with Active Cooling

The device FRIOCELL® provides time and space-precision tempering of materials in the field of bio-technologies, botany, zoology, food processing, cosmetics, chemistry, etc. A unique cooling system offers exact and economic simulation of selected natural processes; it reduces evaporation of samples and allows extremely low temperature conditions regeneration times.

In case of optional equipment buying, the device offers regulation of CO₂ respectively other gases concentration or space-homogenous lighting in the field of visible or UV light with adjustable intensity and possibility of intensity measuring using special probes. Thanks to the unique combination, the device offers a wide range of possible applications to users.

Meeting the requirements of regulations
2006/95/EC, 2004/108/EC, ICH 279/95 Option 2, FDA 21 part 11.



Applications



Pharmaceutical Industry

Tests of photo stability according to ICH 279/95 Option 2, quality tests of pharmaceutical raw materials



Cosmetic Industry

Durability testing, testing of cosmetic products or primary materials stability



Plastics Industry

Temperature stabilisation of reference samples



General and Applied Industry (research field)

E.g. cultivation of tissue cultures – human or animal ones



Food Industry

Tests of food products expiration date



Beverage Industry

Rapid beer quality test
(12h/5°C+12h/40°C)



Water Management

Testing of water quality in municipal water preparing plants (BSK5 at 5°C)

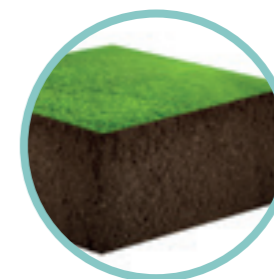

Agriculture

Enzymatic reactions and microbiologic activities in soils



Zoology

Simulation of conditions for living organisms research – cultivation of fish eggs, cultivation of insects development stages



Botany

Studies of germination, green plants growing for further research



Paper Industry

Long-term testing of paper quality



Paints and Varnishes Industry

Paints stability testing – resistance to UV radiation



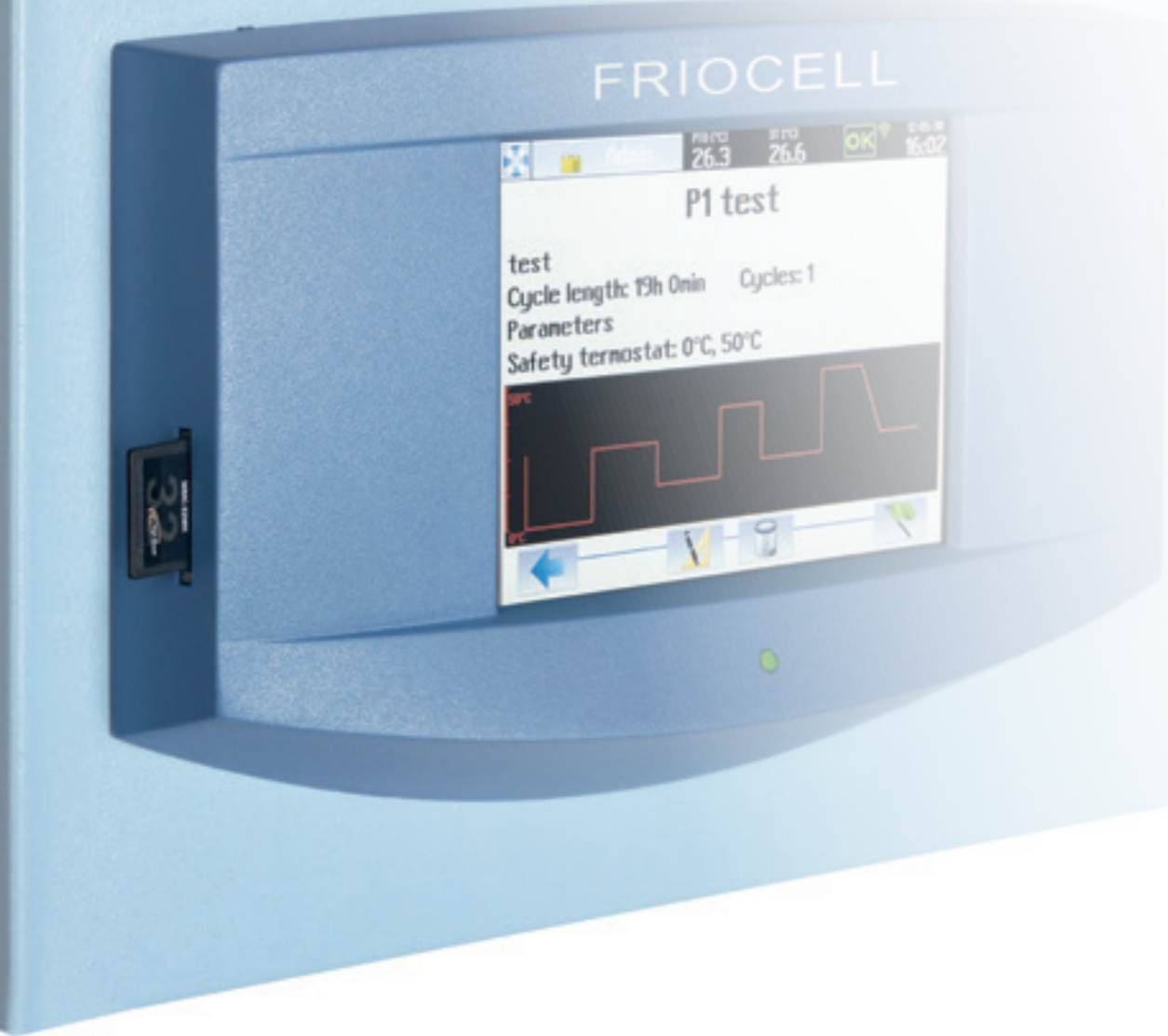

The New Control System Offers

- 5.7 inch (14.5 cm) touch screen display
- Microprocessor fuzzy logic process control
- Intuitive control via colour icons
- Graphic configuration of a new program
- Transparent displaying of data course at the cycle
- Protective thermostat class 3
- Acoustic and visual alarm
- Multi-level users administration (corresponding to FDA 21 Part 11)
- Keyboard lock against unauthorised handling
- Data encryption and non-manipulability (corresponding to FDA 21 Part 11)
- Up to 100 programs and up to 100 segments for each program
- Yearly data logger in graphic and numeric form
- On-line or off-line data export
- Prepared service programs for fast diagnostics of faults
- Easy service diagnostics including remote access
- Multi-language communication
- Direct printing of protocols in PDF format via Warmcomm 4.0
- Easy user configuration of the device
- SD memory card, USB Host and RS 232 standardly included
- WIFI connection, USB device or Ethernet interface with own IP address for remote data transfer, control and diagnostics (optional equipment)
- Programming of ramps, real time and cycling
- Fan setting 0–100%
- Main ON/OFF switch for security reasons
- Device state LED indicator

Connectivity

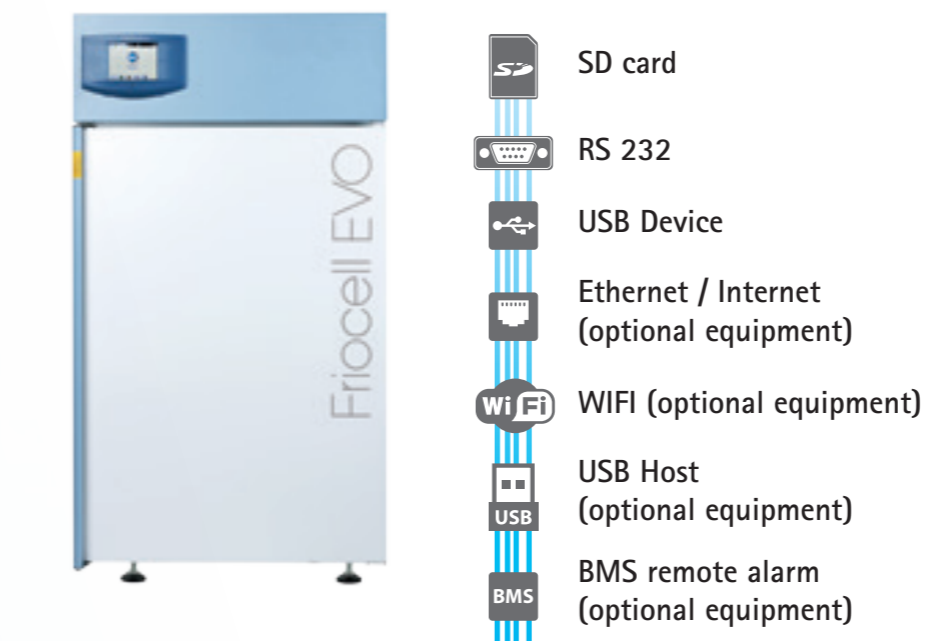

Data Outputs

Thanks to the most up-to-date components of electronic, the device FRIOCELL® EVO does not have any data peripherals connection limit. The basic configuration contains traditional and reliable RS 232, USB Device and the SD card as the data carrier. The device can be easily extended with the Wifi 802.11b/g module with up to 100 meters reach, there is also available the USB Host for bi-directional USB communication and for remote connection there is the Ethernet (RJ 45) connection. Proper IP address allows easy connection to PC or selected printer, respectively other usual data periphery (Smartphone, Netbook, etc.). Thanks to the open platform and adjusted data format it is also possible to configure remote connection and to work with on-line data in remote mode (internet).



WarmComm 4.0

Universal Data Administration with Devices of the MMM Group



- connectible to all the devices of the MMM Group
- stable platform of the SQL library
- user-friendly environment
- Connection via the Ethernet to unlimited number of devices via RS 232,USB, then limited by the number of PC ports
- bilateral communication – data monitoring and device control
- compatibility with older lines of heat technology devices
- Client-Server architecture
- service module for local and remote diagnostics
- three levels depending on client's requirements (B-P-F)
- compliance with FDA CFR 21 Part 11 (version F)
- web support, on-line updates
- protected licence policy
- unpretentious to HW requirements, compatible with MS Windows
- validation documentation IQ/OQ



Comfort Machine with Superior Parameters

MMM Group offers traditionally fully ranged size of the cabinet, from personal size 55 litres, up to new size 1 212 litres, with the best ratio cost/performance. Patented vertical air flow with preheating chamber and asymmetrically perforated panels ensure the well proven vertical spiralled air flow with the best spatial homogeneity.

Deep experience of the factory engineers and many years of careful development help with sophisticated Fuzzy Logic control system. By means of the fuzzy logic are continually evaluated the current process conditions as size of chamber, set parameters, quantity of the samples inside and herewith optimizing heating, cooling and steaming performance.

Practical large and popular door handle, robust wheels with brakes and 220° (with exception of size 1212) openable main door(s) contributes to high user friendly character of the device. Light grey with light blue device colours highlighted by dark blue smiley control panel cause a pleasant feeling of harmony in the user every morning

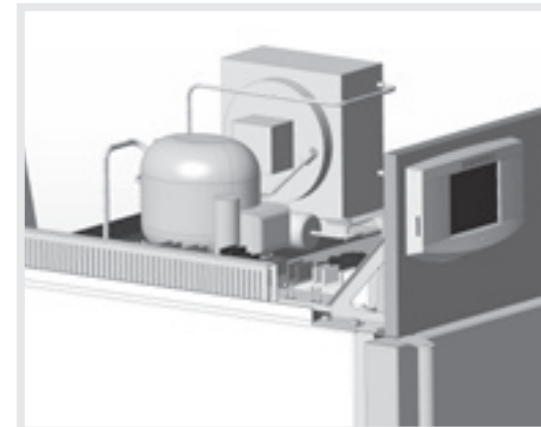

Programmable Exposition Lighting

New generation of the FRIOCELL® EVO device offers wide possibilities of selected lighting use. The variability of placement, selection of light sources, user friendliness and possibility of fluent intensity control meet even the most demanding requirements towards applications with exposition lighting.

Fluorescent Tubes in Doors

Traditional placement of the light cassette with reworked design and increased lighting intensity (up to 36,000 LUX). Even exposition of the whole chamber section with the lowest purchase costs and minimal influence on conditions in the chamber. Regulation of intensity 10-100% in steps of 1%. It can be completed with intensity measuring. Suitable for industrial simulation of ageing or modest processes of growth simulations. Simulation of day and night conditions. Available for FRIOCELL® KOMFORT + FRIOCELL® EVO.

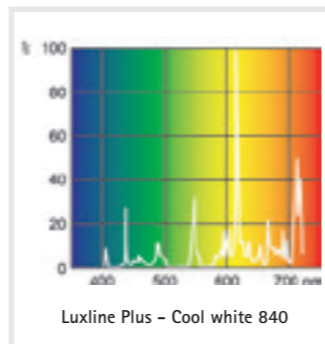

Fluorescent Tubes in Shelves

Vertical source of up to three light cassettes with direct lighting and variable height of exposure. Even exposition of the whole Shelf and optimal use of the chamber volume for the sizes of surface lighting. Efficient balancing of temperature emissions thanks to perforation of cassettes and exact regulation of conditions in the chamber under full exposition. Maximal intensity 20,000 LUX (12 cm below the source). Regulation of intensity 10-100% in steps of 1%. It can be completed with intensity measuring. Typical for tests of photo stability or basic growth simulations in botany. Simulation of day and night conditions. Available for FRIOCELL® KOMFORT + FRIOCELL® EVO.



Various light source colours.

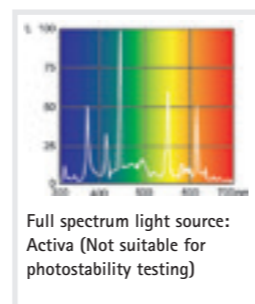
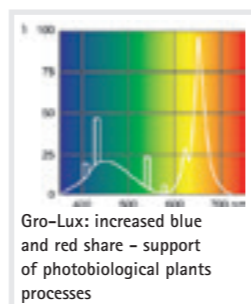
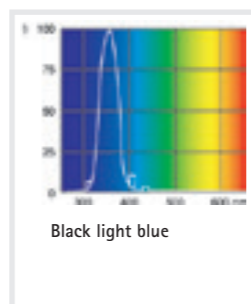
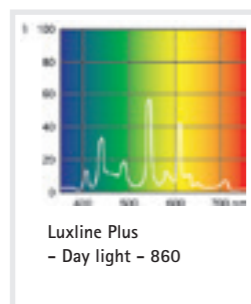
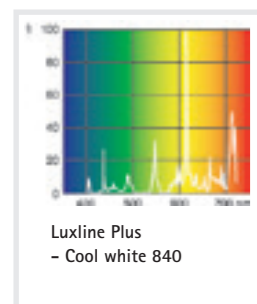

LED Lighting in Doors

Economic solution of white exposition LED lighting with high intensity (up to 21,000 LUX). Even exposition of the whole chamber section with low temperature emissions. Fluent regulation of intensity 10-100% in steps of 1%. Suitable for industrial testing with high requirements towards intensity. Simulation of day and night conditions. It can be completed with intensity measuring. Available for FRIOCELL® EVO.



LED Lighting in Shelves

Exact horizontal lighting with white or colour LED lighting with maximal intensity (up to 30,000 LUX), Low temperature emissions of light source, variability of illuminated cassettes placement and fluent regulation of intensity for each shelf in the range of 10-100% in steps of 1% offers the highest standard of light conditions simulation for industrial use or use in botany. Maximal use of illuminated surface of shelves in relation to the chamber volume. Simulation of day and night conditions. It can be completed with intensity measuring. Available for FRIOCELL® EVO.

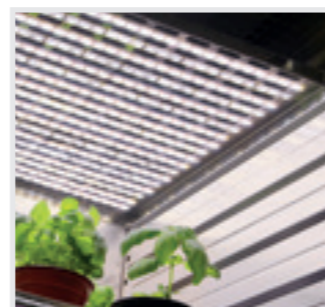

Configuration for typical applications



Based on our experience we offer optimal configurations for selected applications, typical for FRIOCELL®.



Botany

Studies of germination, green plants growing for further research



Pharmaceutical Industry

Tests of photo stability according to ICH 279/95 Option 2, quality tests of pharmaceutical raw materials

Growth Chamber - White



Exact growth chamber with variable growth height and full-spectrum fluently controllable LED lighting.

- Base used FRIOCELL® EVO
- Chamber sizes 111, 222, 404, 707, 1212
- Up to four floors with LED lighting
- Up to 3,4m² of lighted surface
- Full-spectrum stable white LED lighting with fluent intensity regulation (step 1%)
- Maximal intensity up to 330 μmol/m²/s*
- Maximal growth height up to 1300 mm
- Automatic defrosting
- CO₂ regulation (option)

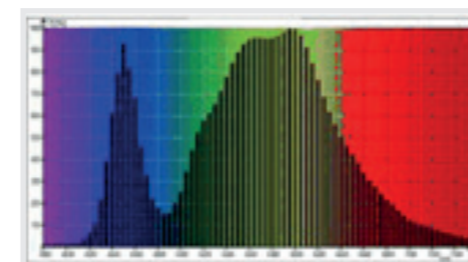

Growth Chamber - Spectral



Growth chamber optimising high lighting intensity with optimal colour spectrum of LED source for photosynthesis and low power consumption.

- Base used FRIOCELL® EVO
- Chamber sizes 111, 222, 404, 707, 1212
- Up to four floors with LED lighting
- Up to 3,4m² of lighted surface
- Diversified blue-red-fared (2:2:1) LED source optimised for photosynthesis with fluent regulation of individual light components
- Maximal intensity up to 311 μmol/m²/s*
- Maximal growth height up to 1300 mm
- Automatic defrosting
- CO₂ regulation (option)

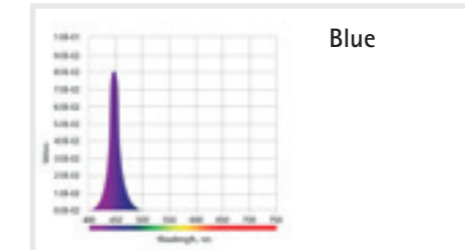
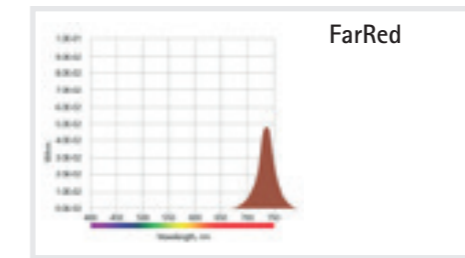
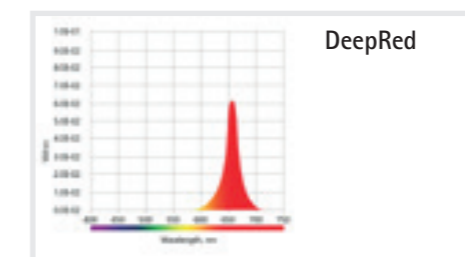
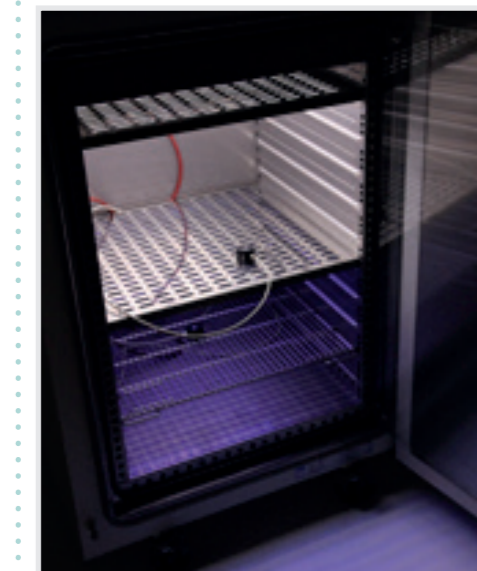

Photo-stable Chamber



Chamber with combined or separated VIS-UV source of light with independent control and automatic assessment of photo stability test.

- Base used FRIOCELL® EVO
- Chamber sizes 111, 222, 404, 707, 1212
- Three combinable VIS-UV lighted shelves or two VIS + one UV lighted Shelf
- Automatic control of process duration
- Automatic assessment of exposure dose (with option VIS and UV measuring)
- High intensity of lighting - up to 20,000 LUX and 3,0 mW/cm²/s-1*
- Short exposition times
- High light homogeneity for equal lighting of all the samples
- Printing of protocols for individual exposition doses with confirmation
- Automatic defrosting



*) measured 12 cm below the Shelf

Accessories Included

Each FRIOCELL® EVO is supplied with standard equipment which does not have to be additionally ordered and it makes a standard part of delivery:



Optional Equipment

Thanks to modular construction of our devices even FRIOCELL® EVO may be additionally equipped according to your preferences with many additional options. FRIOCELL® EVO may then serve as a chamber for testing of photo-stability, light simulation of day and night, processes with CO₂ control, hot-air decontamination, etc.

- | | | |
|----------------------------------|---|--|
| 1. Hot-air decontamination 160°C | 8. CO ₂ control | 15. Programmable inner socket |
| 2. Additional cooling -20°C | 9. Software WarmComm 4,0 | 16. External printer |
| 3. Flexible temperature sensors | 10. Data module USB device, Ethernet, wi-fi | 17. Multi-point temp. / humidity measuring |
| 4. LED light shelves | 11. Mechanic door lock | 18. IQ/OQ protocols |
| 5. Exposition lighting in doors | 12. Electromagnetic door lock | |
| 6. Light sensors of exposition | 13. Trays or shelves | |
| 7. Defrosting system | 14. Access port Ø 25, 50, 100 mm | |

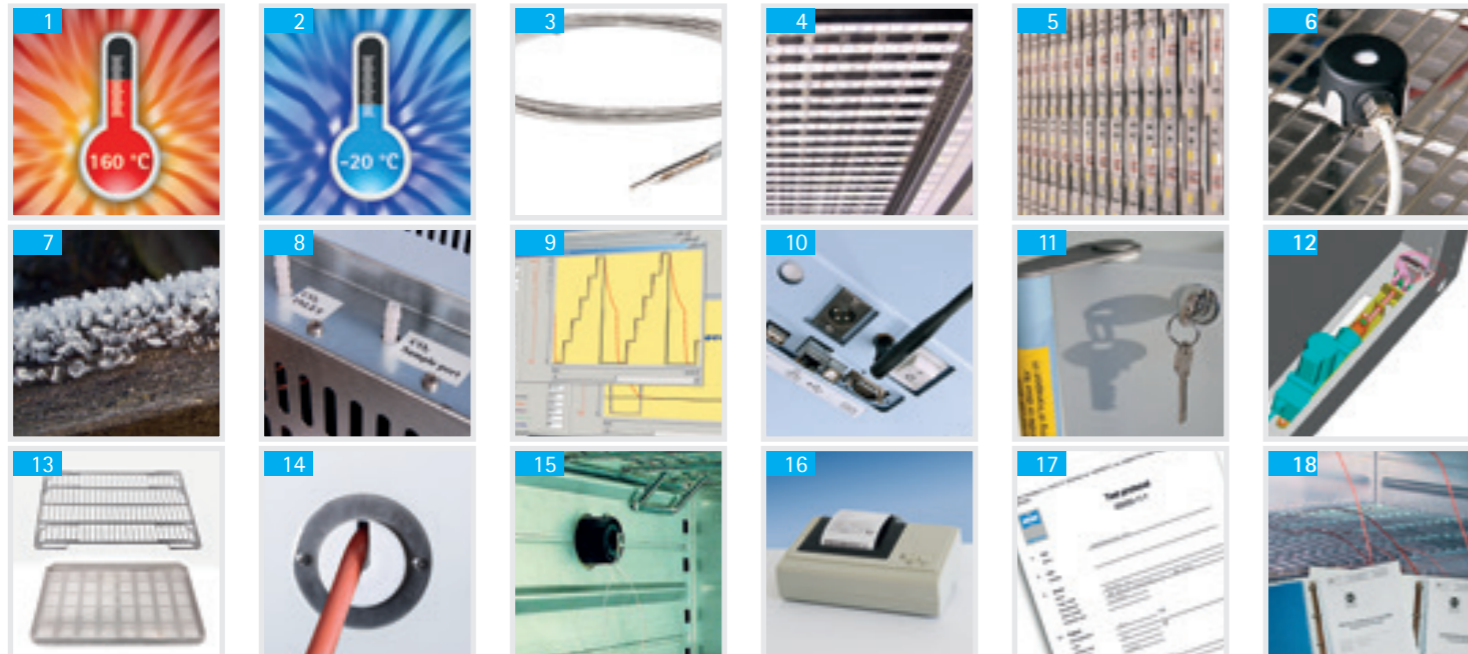

Technical Parameters



FRIOCELL® EVO (FC EVO)			55	111	222	404	707	1212	
Technical data Internal space - chamber, stainless steel DIN 1.4301 (AISI 304)	volume	cca l	54	110	219	404	704	1408	
	width	mm	400	540	540	540	940	3x540 (1905)	
	height	mm	355	535	765	1415	1415	1415	
	depth	mm	380	380	530	530	530	530	
Volume of the steam space		cca l	91	167	305	530	878	1753	
External dimensions (including door, Handle H and caster C)	width	mm	640	780	780	1100	1500	2530	
	height	mm	940H	1187H	1450H	1890C	1890C	1921C	
	depth	mm	755	755	885	885	885	898	
Package - dimensions (three-layers carton)	width	cca mm	990	992	1120	1332	1682	2742	
	height (incl. palette)	cca mm	1300	1650	1746	2200	2190	2240	
	depth	cca mm	830	954	952	1062	1064	1137	
Weight	nett	kg	95/105**	110/120**	143/153**	240/250**	280/290**	519/545**	
	brutt (carton)	kg	180/190**	220/230**	263/273**	390/400**	500/510**	839/865**	
Shelves of stainless steel *)	shelves	max. No.	5	7	10	19	19	3x19	
	standard equipment	pcs. included	2	2	2	2	2	6	
	min. distance between shelves	mm	70	70	70	70	70	70	
	Storage area (w x d)	mm	380x335	520x335	520x485	520x485	920x485	520x485	
Maximal load *)	per 1 tray	kg/screen	20	20	30	30	50	30	
	for a shelf	kg/shelf	20	20	30	30	20	30	
	total inside of device	kg/case	50	50	70	100	130	300	
Number of outer metal doors		psc.	1	1	1	1	2	3	
Number of inner glass doors		psc.	1	1	1	1	2	3	
Electrical data	max. power requirement without decontamination	W	700/850**	1000/1150**	1150/1300**	1700/1700**	2000/2050**	2500/3300**	
	max. power requirement with decontamination	W	700/850**	1000/1150**	1150/1300**	1700/1700**	2600/2650**	2500/3300**	
	mains 50/60 Hz	V	115/230	115/230	115/230	115/230	115/230	115/230	
Protective system			IP20	IP20	IP20	IP20	IP20	IP20	
Temperature data	from 0.0°C	to °C	100 (decontamination 160°C)					70	
	from -20.0°C	to °C	100 (decontamination 160°C)					70	
Temperature accuracy	in space at 10°C	cca (±) °C	<0,5	<0,5	<0,5	<1	<1	<0,6	
	in space at 37°C	cca (±) °C	<0,5	<0,5	<0,5	<1	<1	<0,5	
	in time	cca (±) °C	<0,2	<0,2	<0,2	<0,3	<0,4	<0,2	
Heating/up time to 37°C from the ambient temperature		min	<11	<11	<11	<22	<13	<30	
Cooling/down time from 22°C to 10°C		min	<21/<11**	<21/<11**	<17/<14**	<19/<11**	<21/<22**	<21	
Recovery time after 30 s of door opening according to DIN 12 880	at 37°C	min	<5	<5	<2	<10	6	10	
	at 50°C	min	<6	<6	<3	<13	6	10	
Heat emission at 37°C		cca W	55	70	63	123	148	200	
Complete device noise level		dB	45/50**	46/52**	50/56**	56/58**	58/65**	60	
CO₂ concentration		%	0,1-20					-	0,1-20
Required pressure CO₂		bar/psi	0,3-0,7/5-10**					-	0,3-0,7/5-10**

Note: All technical data are related to 22°C ambient temperature and ± 10% voltage swing (if not specified).
For other parameters see section Electric connections.

*) Approx. 50% of the tray area can be filled in a way a uniform air circulation is enabled inside the chamber.

***) Value at cooling up to -20°C.

The values may differ depending on specific charge and media parameters.

Change in the design and make reserved.



Make Acquaintance With Our Further Offers ...

Laboratory Ovens and Incubators



INCUCELL® / INCUCELL® v

Suitable for safe treatment of microbiological cultures

FRIOCELL®

Cooling incubators

CLIMACELL®

Climatic chambers

CO₂CELL

CO₂ atmosphere

ECOCELL®

The highly cost-effective heating oven series for simple drying processes

DUROCELL

Special- purpose drying ovens DUROCELL with highly resistant EPOLON coating

VACUCELL®

Vacuum drying ovens

STERICELL®

Intended for hot air sterilization of materials under specified temperature and duration.

VENTICELL®

Drying ovens with forced air circulation

Sterilization and Depyrogenation



VENTICELL® IL

series of modular large-sized laboratory devices with the chamber volume of from 700 to 3 900 litres. The devices are used for items sterilization at the temperature of up to 180°C, or for items depyrogenation at the temperature of up to 300°C and optional time mode. The devices can be used in laboratories, industry, pharmacy and research.

Steam Sterilizers (Autoclaves)



STERILAB®

Small steam sterilizer, 25 l



UNISTERI® HP IL

Medium-sized steam sterilizers, 73–254 l



STERIVAP® HP IL

Large steam sterilizers, 148–1 490 l



MMM Group

MMM Medcenter Einrichtungen GmbH, Semmelweisstrasse 6, D-82152 Planegg / München
Tel.: +49 89 8992 2620, Fax.: +49 89 8992 2630, E-mail: medcenter@mmm-medcenter.de, www.mmm-medcenter.de