

Life Science

# CM30 Incubation Monitoring System

Control Your Process with Smart Cell Culture Monitoring



# Transform Your Cell Culture Workflow— From Image Acquisition to Data Creation

Culturing cells can be costly, complicated, and time-consuming. With the CM30 incubation monitoring system, there's a simple way to improve your culture process.

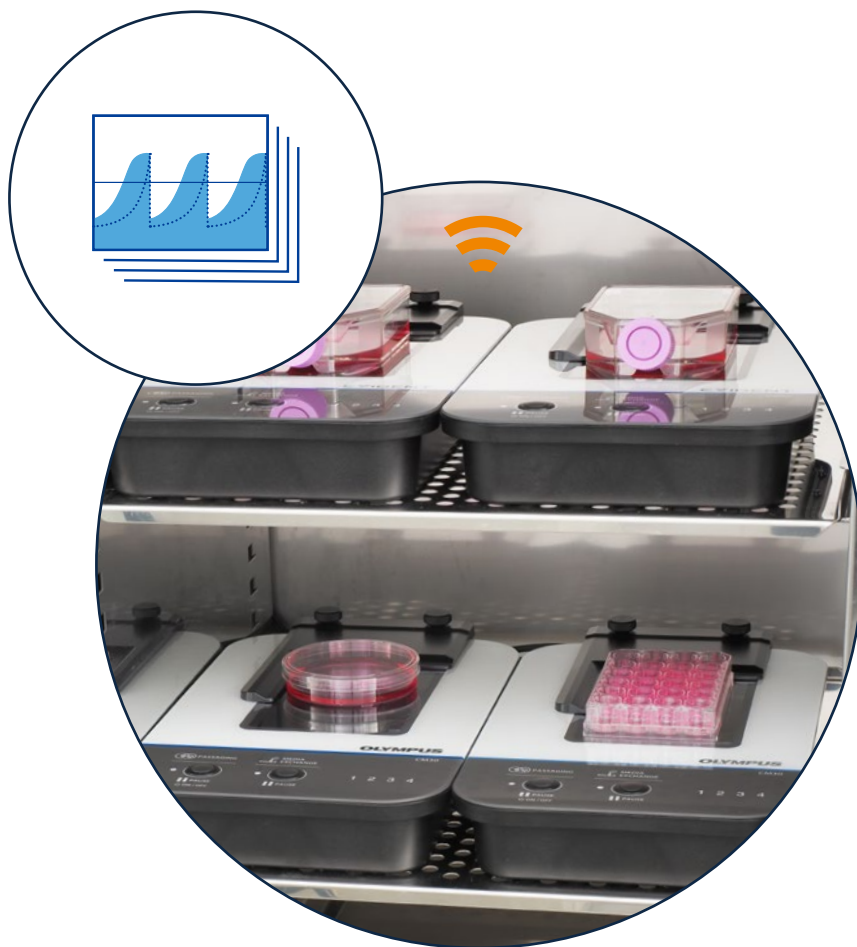

Label-Free, Quantitative Results

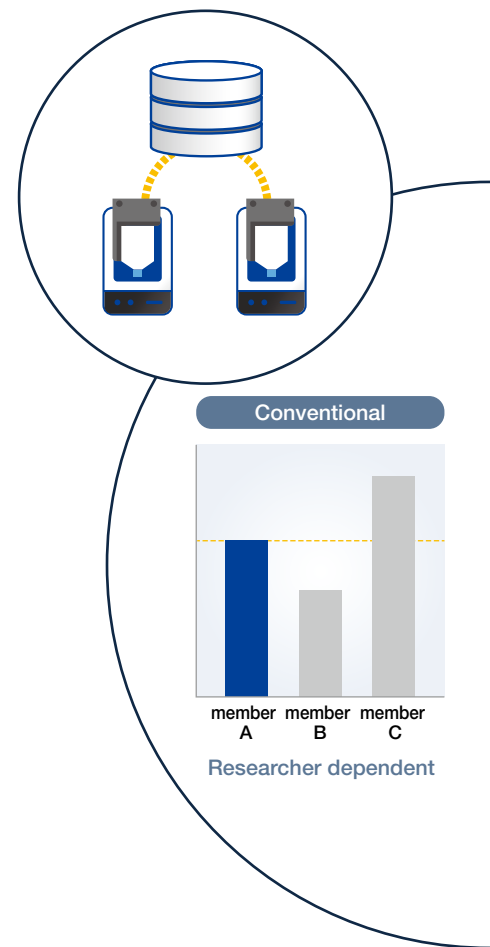

Consistent Results

# More Efficient Cell Culture Monitoring Workflow

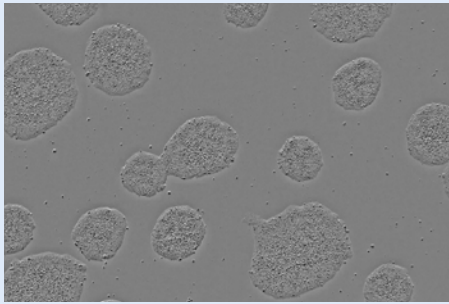
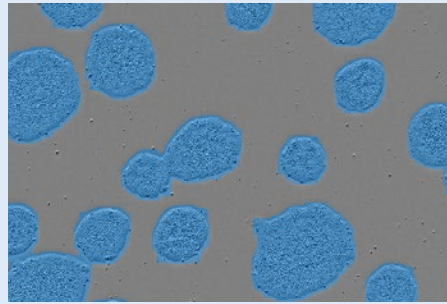
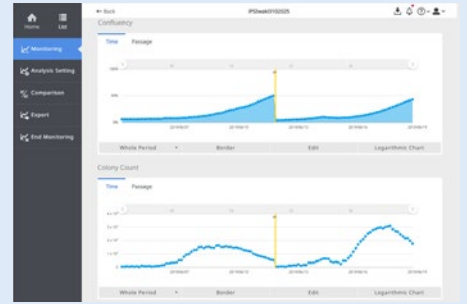

Image acquisition



Analysis



Quantitative data

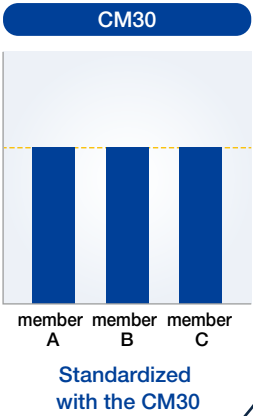

Throughout Your Lab

Cost Effective

# Label-Free, Quantitative Results

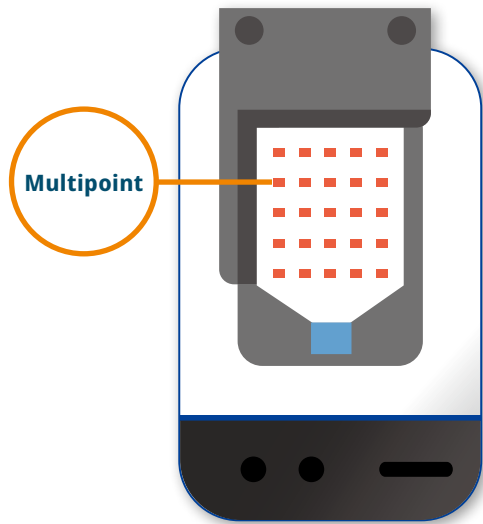

## Multipoint Cell Culture Monitoring

Creating and maintaining a standardized cell culture workflow can help mitigate growth rate variations caused by factors such as contamination, user bias, and cell culture media. The CM30 system's visual information and quantitative records enable you to identify these problems early in the culture process. The monitor scans multiple points and the entire surface in your culture vessel to track the cell culture status. It can also scan multiple wells in a microplate. Choose your own customized monitoring positions or use the predefined templates.

## Label-Free Cell Monitoring

With the CM30 system, there is no need to stain the cultures to monitor their status. It acquires quantitative data from label-free cells, reducing the chance of harm to your cultures.

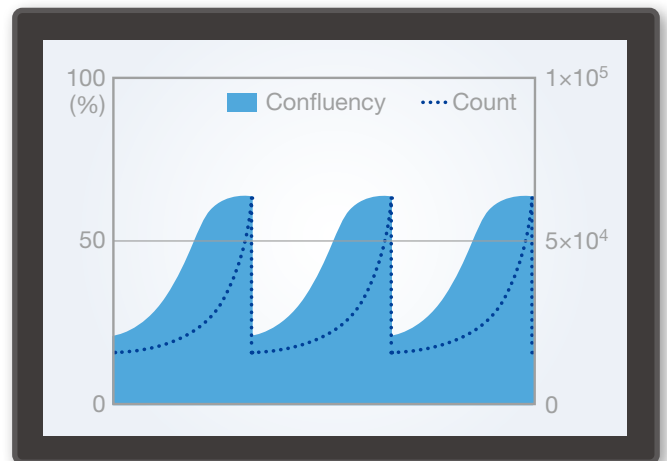

## Leave Your Cultures in the Incubator

The monitor lets you track the health of cell cultures without removing them from the incubator, reducing the risk of contamination or damage from temperature changes and vibration. Its unique design enables you to fit up to four head units inside a standard incubator for greater efficiency.

# Consistent Results Throughout Your Lab

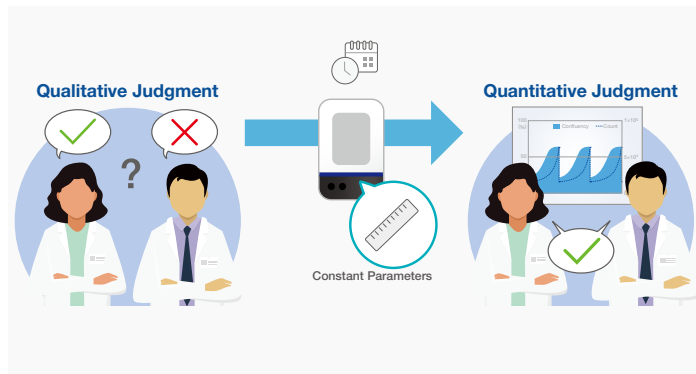

## Constant Analysis Parameters

In a conventional workflow, checking cell cultures was dependent on the experience of the operator, leading to varying results depending on the operator's skill. The CM30 system uses image analysis technology based on machine learning to continuously measure and analyze the images acquired. Constantly visualizing the culture status as a quantitative value eliminates factors that cause variations in cell checks and contributes to the reproducibility and consistency of experiments.

## Compare Data Across Multiple Samples

The system can monitor a variety of vessel types, including dishes, 6- to 96-well plates, and single- and multilayer flasks, enabling you to easily compare quantitative data across a range of culture vessels. Culture status data can also be compared with past measurement data and shared with team members, facilitating controlled experiments and troubleshooting.

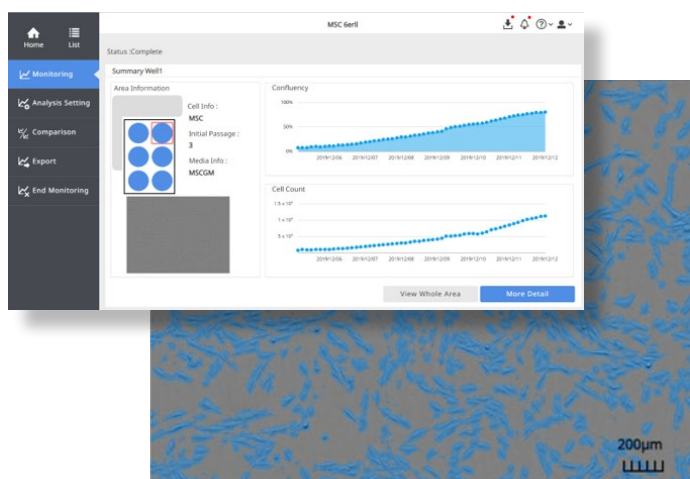
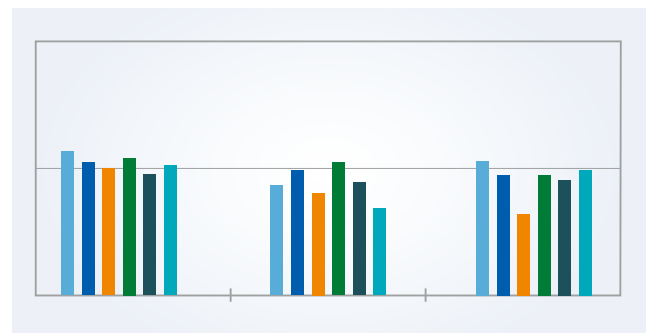
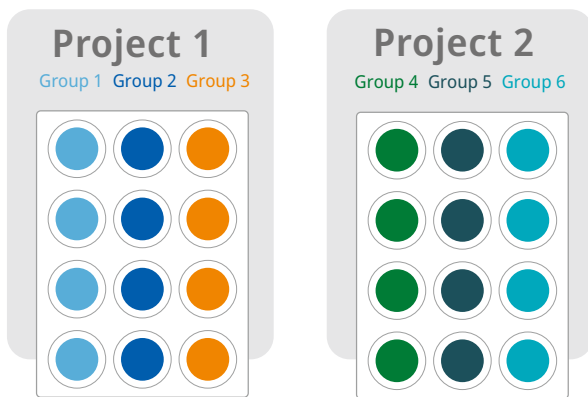
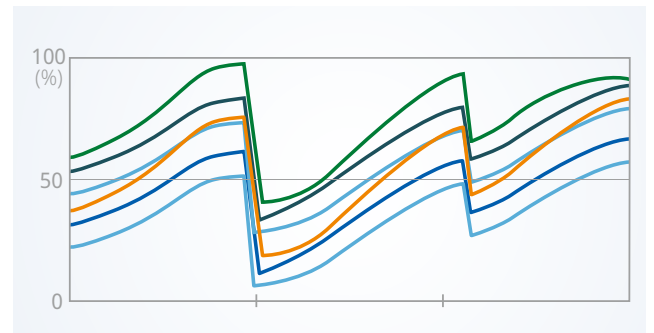

## Customize the Analysis Parameters to Suit Your Experiment

The CM30 system automatically performs confluency, cell counts, and colony counts from acquired images. You can configure the system's analysis parameters to suit each cell culture's variables, such as cell type, culture conditions, or drug administered. Knowing the stepwise cell culture status at each time point improves the accuracy of the experiment.

# Cost Effective

## Save Time with Automation

Improve your traditional microscopy-based workflow and get more accurate results in less time. By automating cell culture monitoring using the CM30 system, you can expand your research and use your time more effectively

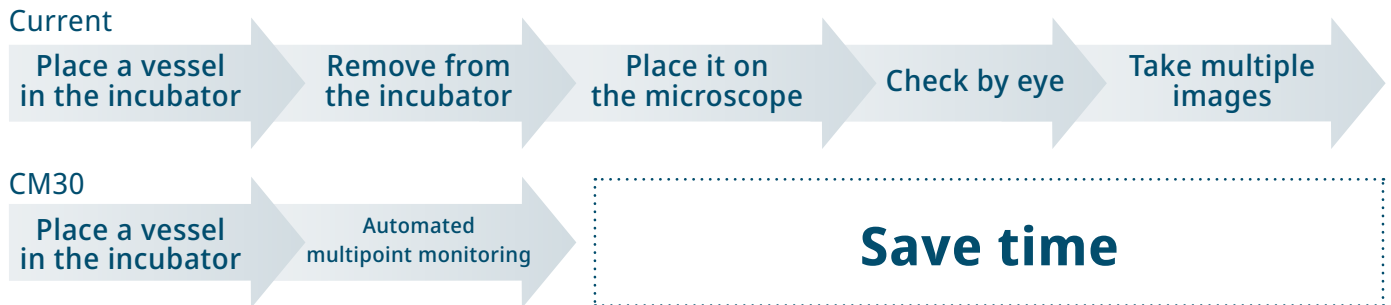

## No Need to Enter the Clean Room for Monitoring

Every time you enter the clean room, there is an operational cost for consumables and measurements. Now, you can reduce your costs by remotely checking the status of your cultures from outside the lab.

## Accurately Time Cell Passage

Time cell passages consistently and without the subjectivity associated with manual evaluation. Based on your set parameters, the software can indicate when your cells are ready for passage, helping to prevent failures.

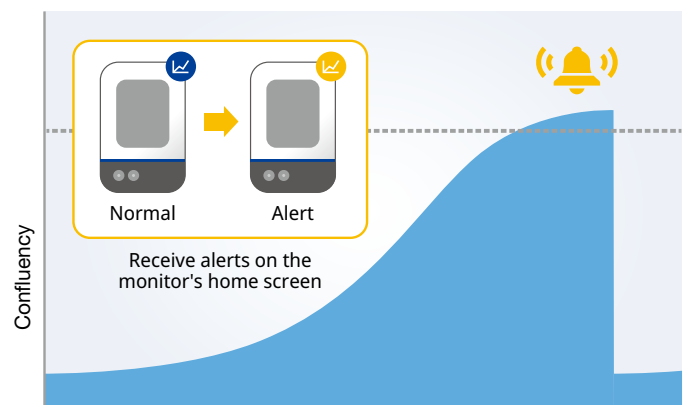

## Supports a Wide Range of Vessel Types

The CM30 incubation monitoring system's epi-oblique optical system enables it to have a compact, flat design that accommodates most standard cell culture vessels, including dishes, 6- to 96-well plates, and single- and multilayer flasks. Also, you can register optional vessels based on your needs\*. Then, simply place the culture vessel you normally use on the CM30 head.



96-well microplate



Petri dish



T75 flask



Multilayer flask

\*Vessel customization is only possible for existing vessel types.

## Sample Images

MSC (Mesenchymal stem cells)

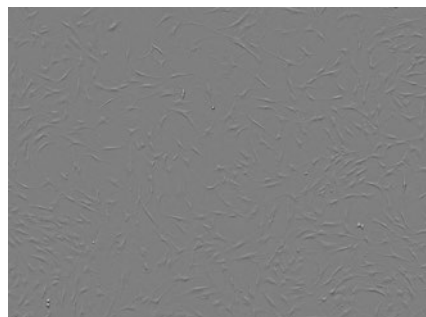

HEK293  
(Human embryonic kidney cells 293)

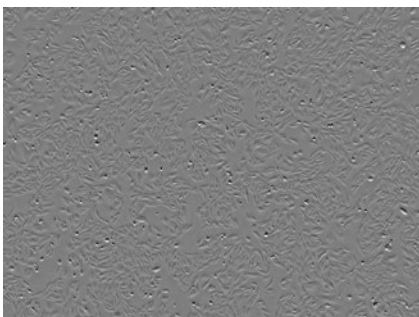

MCF7  
(Human breast cancer cells):  
Scratch assay

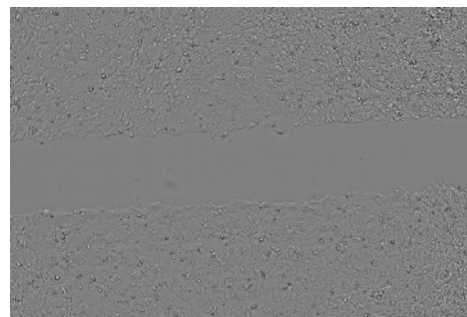
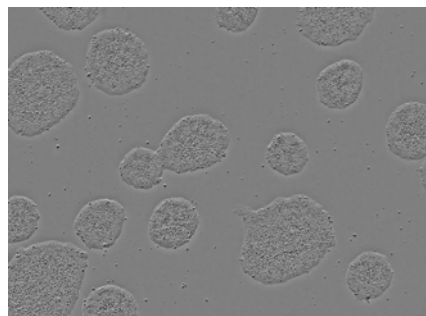
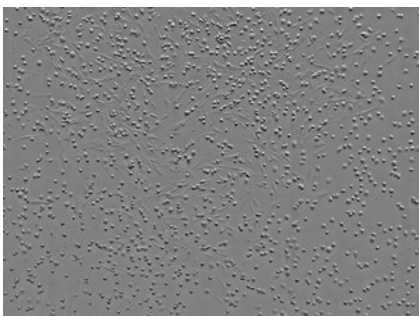

Image data courtesy of: ACEL, Inc.

iPSC (Induced pluripotent stem cells)



HepG2 (Human hepatoma cell line)



See more in our Application Gallery

# CM30 System Specifications

## Hardware

### CM30H: Incubation Monitoring Head

Installation environment (inside the incubator)	Temperature: 37 °C (98.6 °F) ± 0.3 °C (0.5 °F), humidity: 0–99%
Applicable vessels*	Petri dish (90 mm (3.54 in.), 100 mm (3.94 in.)) Microplate (6 well, 12 well, 24 well, 48 well, 96 well) Flask (T25, T75, T80, T150, T175, T225) Multi-layer flask
Optical performance	Field of view (H × V): 2.84 mm × 2.13 mm (0.11 in. × 0.08 in.); (image size per one shooting) Image size: 1280 × 960 pixels Illumination wavelength: λ = 630 nm (LED) Illumination method: epi-oblique illumination
Cable length	Approx. 4.5 m (14.8 ft)
Sterilization resistance	Autoclave sterilization (for vessel holder and sponge rubber only) UV ray sterilization Hydrogen peroxide (H <sub>2</sub> O <sub>2</sub> ) gas sterilization (CM30H only)
Disinfection resistance	Peracetic acid disinfection (cold sterilant) Alcohol disinfection
Weight	Approx. 3.1 kg (6.8 lb)

### Incubation Monitoring Station (recommended system configuration for CM30 software)

OS	Microsoft® Windows® 11 (64-bit) English version
CPU	Intel® Core™ i5 (3.3 GHz) or higher
RAM	16 GB or more
HDD	4 TB or more
Number of connectable CM30H**	Max. 4 heads

## Software

User management	1000 user licenses (max)
Project setting	Project creation: new or load Setting mode: standard or custom Culture conditions: vessel information, culture information etc. Cell analysis conditions: new or load Access authority: public or private Imaging interval: selection type
Analysis	Cell analysis: cell confluency, cell count iPS/ES cell analysis: colony confluency, colony count, colony size Data statistics: growth rate, doubling time
Browsing	Image: entire area (tiling), fixed points Analysis result: graph (time, passage), Multiple data comparison
Export	Data export: image file (jpeg), movie file*** (avi), CSV file*** Import/Export project: the system or the selected data Create report (PDF)
Data management	Record the detection history of stored data

### Client PC (recommended system configuration for CM30 software)

OS	Microsoft® Windows® 10 (64-bit) or higher
CPU	Intel® Core™ i3 (2.1 GHz) or more
RAM	4 GB or more
HDD	Free space: 2 GB or more
Screen resolution	1366 × 768 or more
Web browser	Google Chrome™

\*Additional registration of new manufacturers and model numbers is possible for the above vessels

\*\*The CM20H is also compatible

\*\*\*Only for fixed points

## System Diagram

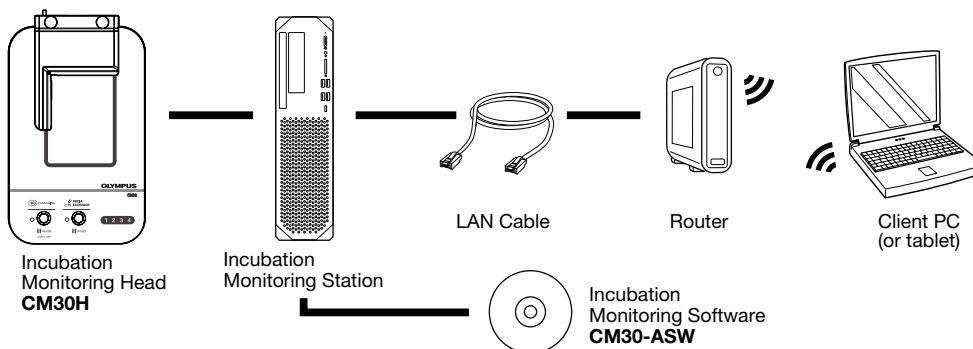

## Dimensions

