

- 1 x True colour 7" Touch Screen Controller
- 1 x Humidity Measuring Sensor with %RH Display
- 1 x Humidity Controlled Air Drying
- 1 x Condensation Humidity Testing Capability
- 1 x Digital Set & Display of Temperature
- 1 x Temperature & Humidity Graphical Logging Facility
- 1 x Automatic Air Purge Facility with Canopy Interlock
- 1 x Timed Test Stop Facility
- 1 x Calibration Certificate
- 1 x Consumables Kit
- 1 x Fallout Measuring Kit
- 1 x Salt Solution Reservoir 90 Litre/23 US Gallon Capacity
- 1 x Interior Viewing Window (unless refrigeration ACC29 option is supplied)
- 1 x Ethernet Communications Port

Technical Specification



Model Range & Ref.:
CCT range, model ref. CC1000iP

Product Description:
 Floor standing cyclic corrosion test chamber

Nominal Capacity:
 1000 Litres/35.3 cu.ft

Dimensions:

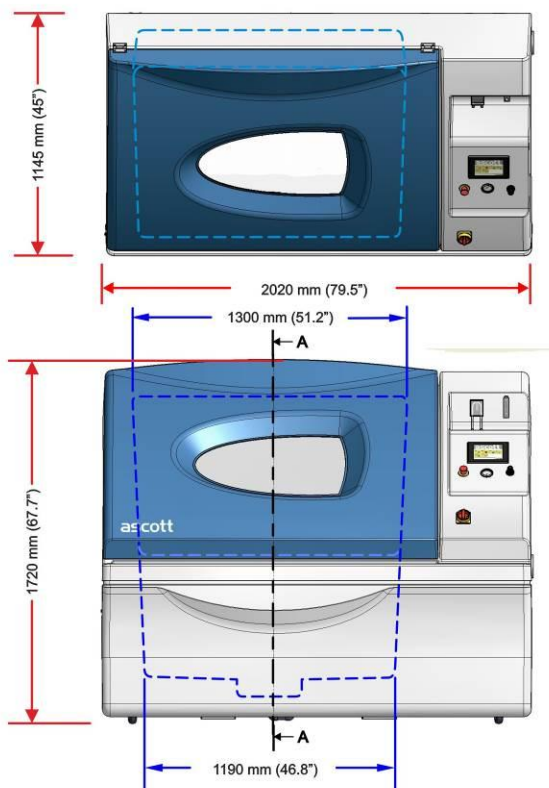

1000 Ltr Corrosion Test Chamber

— External Dimensions
 — Internal Dimensions

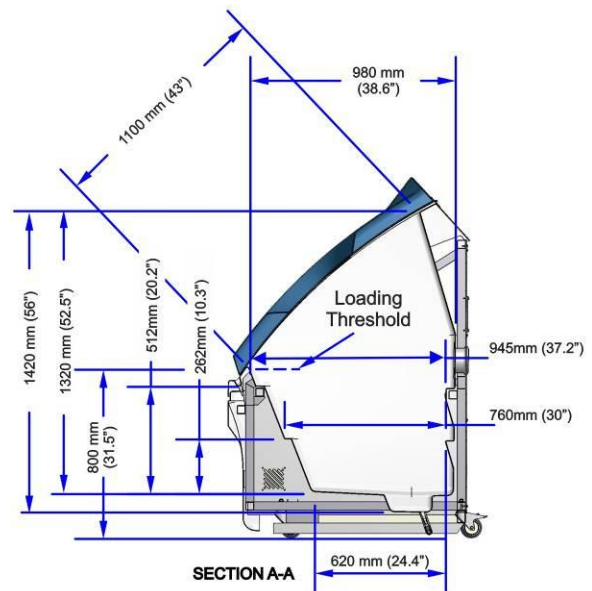

* Note: excludes pipes, cables, etc. for connecting to external service utilities

Salt Solution Reservoir capacity
 (additional capacity can be provided, see optional accessory ACC59)

90 Litres/23 Gallons

Performance

Note: Cross section diagrams are of a 1000L model, for illustration purposes only.

Salt spray mode

Chamber Temperature range:
Adjustable from ambient to +60°C/140°F

Humidity range;
Fixed at 95-100% RH

Salt fog fallout rates:
Adjustable from 0.5 to 2.5ml per 80cm² per hour

Air saturator temperature range:
Adjustable from ambient to +63°C/145°F

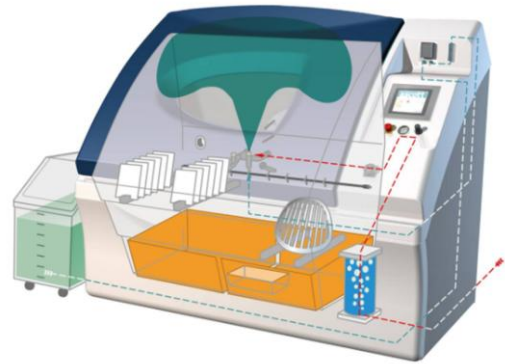

Condensation humidity mode

Chamber Temperature range:
Adjustable from ambient to +70°C /158°F

Humidity range:
Fixed at 95-100% RH

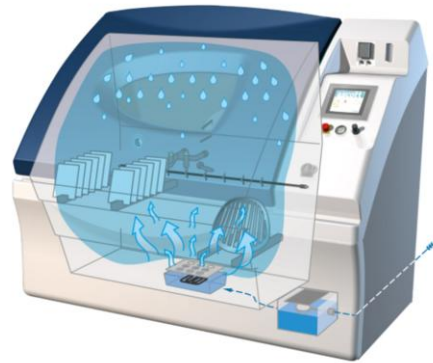

Air drying mode

Chamber Temperature range:
Adjustable from ambient to +70°C/158°F

Humidity range:
Uncontrolled – will reduce to as low as possible

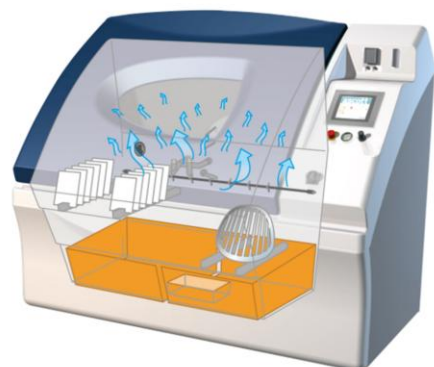

Controlled humidity mode:

Chamber Temperature range:
Adjustable from ambient to +60°C/140°F

Humidity range:
Adjustable (see graph below for range)

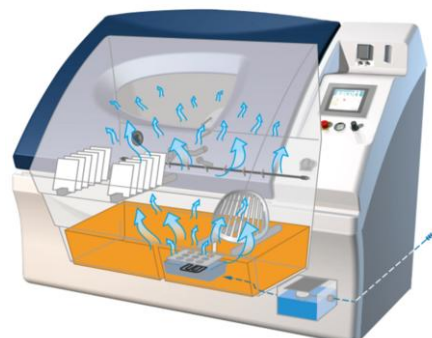

Chamber Tolerances

Temperature Control accuracy $\pm 0.75^{\circ}\text{C}$

Temperature fluctuation within workspace $\pm 0.75^{\circ}\text{C}$

Temperature variation across workspace $\pm 1.5^{\circ}\text{C}$

Relative Humidity control Accuracy $\pm 3\% \text{ RH}$

Relative Humidity fluctuation within chamber workspace: Subject to temperature and fluctuation, typically $\pm 3\% \text{ RH}$

Relative Humidity variation across workspace:- Subject to temperature, but typically $\pm 5\% \text{ RH}$

Humidity Range

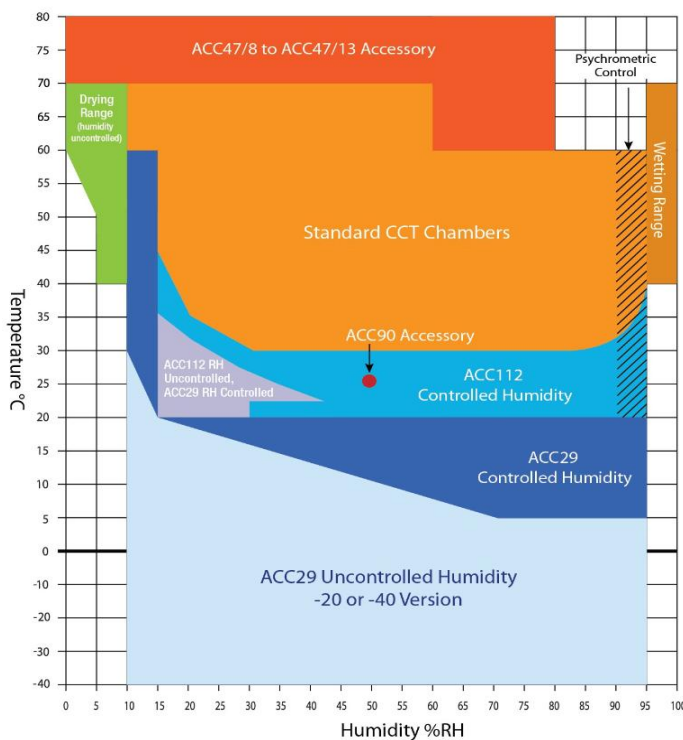

Notes to the graph:

The performance, accuracy and stability of the chamber depends directly upon the ambient temperature/humidity of the air in the room in which the chamber is located. This is assumed to be no greater than $23^{\circ}\text{C}/73^{\circ}\text{F}$ 50% RH for the adjacent graph.

The chamber will operate in ambient conditions of up to $30^{\circ}\text{C}/90^{\circ}\text{F}$ and 85% RH (non-condensing) however, the minimum operating temperature/humidity that can be controlled inside the chamber, will be reduced.

As well as performing to the requirements of the traditional ASTM B117 based, continuous salt spray test standards. This chamber is also equipped with a control system to enable it to perform cyclic corrosion tests. These tests usually comprise of sequential periods of:

1. Salt spraying,
2. Controlled humidity air drying,
3. Condensation humidity (wetting).

The programmable control system fitted, enables the above conditions to be arranged in any sequence and permits other events to be programmed in between e.g.; cold air blow. Also the duration of each event and number of times the whole cycle is to be automatically repeated, can be varied.

Up to 254 multi-step cyclic programmes, 200 sub programs and 254 single step/single set point programs can be created and stored in the controller's system memory for subsequent execution by the chamber.

Program Menu
ESC

View, Edit, delete or create new test profiles.

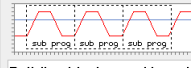
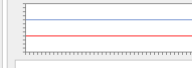
Main Programs	Sub Programs	Single Line
 Complete test profiles, containing more than one step.	 Building blocks used in main programs. Ideal for programs with lots of repetition.	 One step programs. Ideal for testing and calibration.
Select	Select	Select

18:35:01
29/01/2021
No Faults Detected
Stopped

Test Standards Complied with:

For a full summary of this chambers test standard compliance please visit our website at: www.ascott-analytical.com

Construction

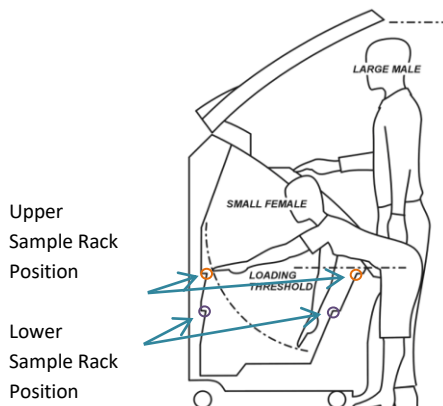

- ✓ A low front loading threshold, to ease loading and unloading of samples, especially from the back of the chamber.
- ✓ All plastic construction giving a high quality, durable and corrosion resistant finish.
- ✓ High and low level positioning for sample racks enabling small and/or large test samples to be accommodated.

- ✓ Large 90L/23 US Gallon capacity salt solution reservoir with transparent front, enabling continuous unattended salt fogging for periods of up to 5 days (additional capacity can be provided if required).
- ✓ The chamber automatically purges before the canopy opens to minimise the risk of highly corrosive salt fog escaping into the laboratory.
- ✓ Dry seal canopy gasket, so no more wet clothes when loading and unloading chamber!
- ✓ The canopy is pneumatically operated for ease of opening and closing the chamber safely, at the push of a button.



Operation & Control

- ✓ Salt spray pre-humidification via an air saturator, ensuring salt spray is moist and will not clog atomiser jet. The reservoir is filled automatically for continuous unattended testing.
- ✓ Peristaltic pumping of salt solution enabling salt to be delivered at a precisely metered rate.
- ✓ Digital precision temperature controls, guarantees accuracy and repeatability of results.
- ✓ Graduated salt solution flowmeter for quickly assessing and adjusting the salt solution flowrate.
- ✓ Wall mounted heater mats enabling uniformity of temperature through the chamber with maintenance free durability.
- ✓ Air saturator low water and over temperature protection for fail safe operation.

Key Features

Touch screen full colour controller



This Human Machine Interface (HMI) features a full colour 7" 'touch' activated screen, with a 480p (0.38 megapixel) high resolution display, and a 'menu' driven icon based commands, available in multiple languages for ease of understanding and use.

In addition to standard continuous salt spray testing, this enables it to be readily programmed for automatic testing. 254 Multi-step, complex test cycles can be programmed easily with up to 200 steps, as well as 254 single set point steady state control in any operating mode. Temperature and Humidity monitoring available in SCADA using OPC-UA

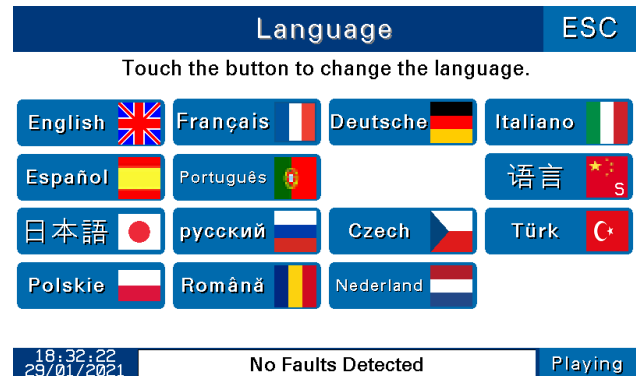

Humidity measuring sensor with %RH display

This chamber is fitted with a state of the art electronic humidity sensor which measures the relative humidity inside the chamber and displays this at the HMI as %RH.

Humidity Controlled Air Drying

During this mode of operation, moisture evaporated from the sump in the base of the chamber is blended with fresh, temperature controlled air, drawn into the chamber from the room in which it is located. The blend of humid air to dry air is determined by the user programmable setting of the chamber control system and creates a precisely controlled temperature and humidity climate inside

Condensation humidity testing capability

Enables the chamber to be used for condensation humidity testing, as well as salt spray testing. Includes a display of relative humidity (%RH) in HMI, measured using a novel design of salt resistant humidity probe.

Digital Set & Display of Temperature

The chamber and air saturator temperatures are monitored by PT100 precision temperature sensors and displayed digitally, to a resolution of 0.1°C, alongside the desired set temperatures.

Temperature & Humidity graphical logging facility

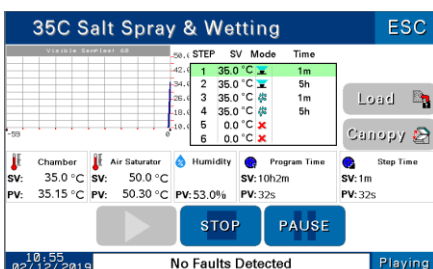

Graphical logging of actual temperature and humidity achieved in the chamber, compared to the set temperature and humidity required, over time. This provides at-a-glance monitoring of chamber performance and the ability to play back and review the chambers performance over the past 168 hours, at the control panel HMI.

Automatic Air Purge Facility With Canopy Interlock

At the touch of a button on the control panel HMI, automatic purging of the chamber interior is initiated. This disperses any salt fog, to minimise the risk of highly corrosive salt fog escaping from chamber into the laboratory. After a pre-set period of purging the chamber canopy can be opened.

Timed test stop facility

Allows the convenience of pre-programming a stop time, at which point the chamber automatically stops testing.

Calibration Certificate



A calibration certificate for the chamber temperature and humidity controller will be provided which will be fully traceable to UK national standards. Single point temperature and humidity calibration is provided free of charge, as standard. Additional points may be available on request at extra cost.

Salt Solution Reservoir – 90 Litres/23US Gallons

A 90 Litre/23 US Gallons capacity salt solution reservoir. With a graduated scale in litres, a lid for ease of filling and cleaning

Interior Viewing Window

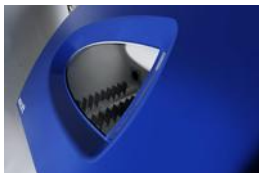

The chamber canopy incorporates a window, as standard, which enables visual checking of the samples inside the chamber, whilst under test. Interior illumination is also available as an optional accessory (Ref.: ACC26).

Note: Viewing window not supplied if ordered with any refrigeration option (ACC29).

Ethernet Communications Port

Enables the chamber to be programmed & monitored via a remote computer, running appropriate software (Ascott optional accessory; ACC121).

Consumable spares kit



A pack of consumable spares, comprising of: 5 packs of salt solution filters, 2m peristaltic pump tubing 1x humidity sensor Filter cap & O Ring, Salt Filter Housing Tube & replacement air filter for micron filter.

Fallout Measuring Kit – Ref.: ACC108



This comprises of 4 x 100ml measuring cylinders and 4 x 100mm funnels

Alternative canopy colour – Ref.: ACC60/**(see below)

As standard, and unless otherwise specified, chambers will be fitted with a blue coloured canopy (RAL5005). By specifying this 'no cost' option, the canopy colour can be changed to one of the following colours:

Note: Colours shown are for representation purposes only.



Blue (RAL 5005)



Grey (RAL 7035)



Light Green (RAL 6027)



Mauve (4005)



Orange (RAL 2009)



Red (RAL 3003)



Red/Violet (RAL 4002)



Turquoise (BS5252 16-E-56)



Yellow (RAL 1028)

Other colours may be available on request and subject to additional charges.

If any canopy colour, other than the blue colour fitted as standard, is required, then this must be clearly stated on customer purchase orders.

Optional Accessories

ASCOTT ANALYTICAL EQUIPMENT LIMITED TERMS AND CONDITIONS OF SALE

1 Definitions

1.1 In these conditions these words have the following meanings:-

"Business Day"	a day (other than a Saturday, Sunday or public holiday) when banks in London are open for business;
"Conditions"	the terms and conditions set out in this document as amended from time to time;
"Contract"	the contract between the you and us for the sale and purchase of the Goods and/or Services in accordance with these Conditions.
"Contract Price"	has the meaning given to it in clause 4.1;
"Goods"	the whole or any part of the goods which we agree to supply to you pursuant to an Order;
"Liability"	the liability for any and all damages, losses (including without limitation any direct or indirect consequential losses), claims, proceedings, actions; awards, expenses, costs and any other losses and/or liabilities;
"Order"	your order for the Goods and/or Services, as set out in your purchase order form or in your written acceptance of our quotation, as the case may be;
"Services"	the whole or any part of the services we agree to provide to you;
"Warranty"	has the meaning given in clause 13.1;
"we", "us" and "our"	Ascott Analytical Equipment Limited (registered in England and Wales with company number 02590442); and
"you", "your" and "yourself"	the customer to whom we supply the Goods and/or Services.

1.2 In these Conditions, the following rules apply:

- 1.2.1 **A person includes a natural person, corporate or unincorporated body (whether or not having separate legal personality);**
- 1.2.2 **A reference to a party includes its personal representatives, successors or permitted assigns.**
- 1.2.3 **A reference to a statute or statutory provision is a reference to such statute or provide as amended or re-enacted. A reference to a statute or statutory provision includes any subordinate legislation made under that statute or statutory provision as amended or re-enacted.**

2 Basis of Contract

- 2.1 The Contract will be governed by these Conditions to the exclusion of any other terms and conditions that you seek to impose or incorporate, or which are implied by trade, custom, practice or course of dealing. These conditions will override any terms or conditions stipulated or referred to by you in your Order or pre-contract negotiations.
- 2.2 Unless otherwise agreed in writing by us no oral warranties, representations or variations to these Conditions or your Order shall bind us. The words "unless otherwise agreed in writing by us" in these Conditions means unless otherwise agreed in writing and signed by one of our Directors.
- 2.3 Even if it is not expressly stated, any Order placed by you and our acceptance shall still be subject to these Conditions.
- 2.4 We may correct any clerical or typographical errors made by our employees at any time and both you and we will be bound by the corrected version.
- 2.5 In these Conditions "Incoterms" means the international rules for the interpretation of trade terms of the International Chamber of Commerce 2020 or any subsequently published set of those rules as in force at the date when the Contract is made. Unless the context otherwise requires, any term or expression which is defined in or given a particular meaning by the provisions of Incoterms shall have the same meaning in these Conditions, but if there is any conflict between the provisions of Incoterms and these Conditions, the latter shall prevail.

3 Quotations and Orders

- 3.1 The Order constitutes an offer by you to purchase the Goods in accordance with these Conditions. You are responsible for ensuring that the terms of the Order and any applicable specification are complete and accurate.
- 3.2 The Order shall only be deemed to be accepted by us by whichever is the earlier of

- (a) our written acceptance of the Order;
- (b) delivery of the Goods or commencement of the Services; or
- (c) submission of our invoice

at which point the Contract shall come into existence.

- 3.3 A quotation for the Goods or Services given by us shall not constitute an offer. A quotation shall only be valid for a period of 60 Business Days from its date of issue, unless agreed otherwise by us in writing. For the avoidance of doubt, we reserve the right to refuse any Order submitted by you.

4 Prices

- 4.1 Subject to the remaining provisions of this clause 4, the prices for all Goods and/or Services shall be those set out in our quotation or as agreed otherwise between you and us in writing ("**Contract Price**").

- 4.2 Unless otherwise agreed in writing by us, the Contract Price is exclusive of

4.2.1 the costs of obtaining or preparing any necessary export documents (including import, export or customs clearances, declarations or licences);

4.2.2 any applicable value added tax, customs, excise, sales taxes, charges, duties or levies which are charged or imposed by any competent fiscal authority in respect of the sale, exportation or importation of the Goods into the country which the Buyer is resident or delivery is to be effected or necessary to enable delivery of Goods;

4.2.3 postage, packaging carriage, freight, handling, loading and unloading and insurance.

all of which shall be for you to account and/or shall be payable forthwith to us (where applicable and/or where necessarily paid by us), in addition to the Contract Price.

- 4.3 Port surcharges and other incidental charges are not included in the freight rate and will be you to account

- 4.4 We reserve the right by giving notice to you, to increase the Contract Price of the Goods and/or Services to reflect any increase in the cost to us which is due to any factor beyond our control (including, without limitation, any foreign exchange fluctuation, currency regulations or alteration of duties, any change in delivery dates, quantities, or specifications for the Goods which is requested by you or any delay caused by any instructions from you or failure by you to give us adequate information or instructions.

- 4.5 While we try to ensure that all prices for the Goods and/or Services which are provided in our quotations are accurate, errors may occur. If we discover an error in the price of the Goods and/or Services before the Contract has been made, we will inform you as soon as possible and may give you the option of re-submitting your Order at the correct price. If we discover an error in the price of the Goods and/or Services after the Contract has been made, we will inform you as soon as possible and will give you the option to vary the Contract at the correct price. If we are unable to contact you or you do not agree to vary the Contract Price, we will cancel the Contract. If the Contract is cancelled and you have already paid for the Goods and/or Services, you will receive a full refund.

5 Payment

- 5.1 Unless otherwise agreed in writing by us, if you are a customer ordering Goods and/or Services for delivery or performance in the UK you will pay in British pounds sterling:

5.1.1 25% of the price of the Goods and/or Services upon placing your Order with us; and

5.1.2 the balance of 75% of the price of the Goods and/or Services within 30 Business Days of delivery and/or performance.

- 5.2 If you are a customer ordering Goods and/or Services for delivery or performance outside the United Kingdom you will pay in British pounds sterling:

5.2.1 in full upon placing your Order with us; or

5.2.2 by letter of credit. If paying by letter of credit you shall, as a condition of any Order for Goods and/or Services being binding upon us, open an irrevocable letter of credit in a form to be approved by us in writing which is confirmed and payable at sight at a UK bank in favour of us for the price payable under the relevant Order and remaining valid for at least 90 Business Days from the date of your Order. All costs and fees associated with the issue and confirmation of such letter of credit shall be borne by you and where any such costs and fees have to be paid by us then you shall increase the value of the letter of credit so that we will receive as a net amount the price payable under the relevant Order.

- 5.3 If you fail to make payment by the due date we may, without prejudice to any other rights or remedies we may have, charge interest (both before and after judgment) on the amount unpaid at whichever is the greater of the rate of 2.5% above the base rate from time to time of Barclays Bank plc, compounded with monthly rests, or the rate of interest prescribed by law.

- 5.4 Time for payment shall be a condition of this Contract.

- 5.5 You shall pay all amounts due under the Contract in full without any set-off, counterclaim, deduction or withholding (except for any deduction or withholding required by law). We may at any time, without limiting any other rights or remedies we may have, set off any amount owing to us by you against any amount payable by us to you.

6 Cancellation

- 6.1 Orders placed by you may not be withdrawn, cancelled, or altered prior to acceptance by us, except as the we may agree in writing at any time prior to acceptance. No Order which has been accepted by us may be cancelled by you except with the agreement of us and on terms that you shall indemnify us in full of all loss, costs (including cost of all labour and materials used), damages, charge and expenses incurred by us as a result of such cancellation.
- 6.2 Goods returned without our consent will not be accepted for credit.

7 Specification

- 7.1 You are responsible for checking any specification provided in our quotation is accurate and adequate for the manufacture and/or provision of Goods and/or Services. We shall have no Liability for errors in any specification or details supplied by you.
- 7.2 Any technical literature, illustrations, descriptions or specifications in our catalogues, price lists or other advertising material are intended merely as a guide and to present a general approximation of the Goods and/or Services. The contents of such literature will not be binding on us and will not form a representation or form part of the Contract nor shall they have any contractual force.
- 7.3 Any specification supplied by us to you, or specifically produced by us for you, all inventions, patents, copyright, design rights (whether registered or unregistered), trade marks (whether registered or unregistered) and/or know-how and/or any other intellectual property rights in the specification, in the Goods and/or arising as a result of our performing the Services and the right to apply for such rights shall be owned exclusively by us absolutely. In particular, no licence is hereby granted directly or indirectly under any patent, invention, discovery, copyright or other intellectual property right held, made, obtained or licensable by us now or in the future.
- 7.4 You shall not disclose to any third party or use any such specification referred to in Clause 7.3 except to the extent that it is or becomes public knowledge through no fault of yours, or as required for the purpose of the Contract.
- 7.5 You agree that, at your cost, you will do all acts and/or execute all documents and/or deeds which are necessary or desirable to give effect to Clause 7.3.
- 7.6 You shall not make any modification to the Goods or their packaging, nor alter, remove, or tamper with any trade marks used on or in relation to the Goods and/or Services.
- 7.7 We reserve the right to make any changes to the specification for the Goods and/or Services if we are required to by law or in order to comply or conform with applicable safety requirements or manufacturing requirements provided that such changes do not have a material adverse effect on the quality and/or performance of the Goods and/or Services.

8 Delivery of Goods or Completion of Services

- 8.1 Delivery of the Goods shall take place and risk in Goods will pass in accordance with Incoterms as applicable and unless agreed with you otherwise, delivery of the Goods shall take place and risk in Goods will pass in accordance with Ex Works.
- 8.2 Any dates that we give you for delivery and/or performance are estimates only and are also conditional upon us promptly receiving from you, final instructions for delivery and/or performance. Time is not of the essence in relation to such dates and we will not be responsible and have not liability for any failure to deliver or complete by such dates.
- 8.3 Unless otherwise agreed in writing, you shall be responsible (at your own cost) for all arrangements for loading (EXW) and unloading the Goods when the Goods are at your disposal for collection or (if other Incoterms are agreed) delivered to you. Where Goods are being delivered in accordance with DAP (at buyer's premises) you will make sure that we are able to access the address for delivery in order to deliver the Goods. Delivery for Goods taking place in accordance with DAP will be made between 9.00am and 5.00 pm on a Business Day.
- 8.4 Where Goods are to be placed at your disposal for collection in accordance with EXW then you shall collect the Goods between 9:00 am and 5:00 pm Monday to Thursday & 9:00 am and 12:00 noon Friday, within 7 Business Days of our notifying you that the Goods are ready for collection.
- 8.5 If you fail to take delivery of the Goods or any part of them and/or fail to provide any instructions, documents, licences or authorisations required to enable to Goods to be delivered on the delivery date, we shall be entitled to store or arrange the storage of the Goods and then notwithstanding 8.1 risk in the Goods shall pass to you, delivery shall be deemed to have taken place and you shall pay us all costs and expenses including storage and insurance charges (where applicable) arising from such failure. We shall not be liable for any costs incurred for whatever reason after delivery of the Goods is deemed to have taken place. Where the Goods are sold inclusive of any or all of the freight, handling, port or insurance charges, any increases in, or in the rate for, such charges arising after the date of the contract and before the Goods are delivered or arising through deviation to a new port at your request or through any delay however caused by you, shall be for your account.
- 8.6 We will have no Liability if we are prevented or delayed from performing our obligations under the Contract due to matters beyond our reasonable control or by reason of your failure to provide to us adequate instructions that are relevant to the supply of Goods and/or Services and their delivery, and in such circumstances we may choose to suspend our performance or cancel the Contract without this suspension or cancellation affecting our right to recover all sums owing to us in respect of Orders or parts of Orders already delivered and/or costs incurred at that date. Matters beyond our reasonable control shall

include but not be limited to rules, regulations, requisitions or orders of the Government or a Local Authority, war, strike, accident, fire, flood, earthquake, pandemic, import or export regulations, or shortages of labour or materials or non-delivery by our suppliers or damage to or destruction of the whole or part of the Goods.

- 8.7 We reserve the right to despatch and invoice any part of your Order when it is available or any part of the Services when such part is completed.
- 8.8 We will try to accommodate you if you make a reasonable request for postponement of delivery, but we shall not be obliged to do so. Where delivery is postponed for a reason other than our fault, you shall pay all costs and expenses of delay including a reasonable charge where applicable, for storage and transportation.
- 8.9 Unless otherwise expressly agreed in writing, Goods sold C.I.F will be insured from the time the Goods leave our premises, warehouse or place of storage at the commencement of transit, through the ordinary course of transit until the named port of destination. Insurance for Goods sold C.I.F shall be effected by us on your behalf. All special risk involved in the carriage of Goods shall be for your account. All costs arising from insurance being effected at your request on Goods sold other than C.I.F, shall also be for your account.

9 Your duty to comply with import legislation and regulations

- 9.1 **You shall be responsible at your own cost for complying with any legislation or regulations governing the importation of the Goods into the country of destination and for payment of any duties thereon.**
- 9.2 **You are responsible for obtaining at your own cost, such import license and other consents in relation to the Goods as are required from time to time and if required by us, you shall make those licenses and consents available to the us prior to the relevant shipment.**
- 9.3 **We may assist you in obtaining such customs declarations as are necessary.**

10 Installation and other Services

- 10.1 If the presence on site of one of our authorised service engineers is required for installation and/or commissioning, we shall be entitled to charge in addition to the Contract Price. In cases where the Contract Price includes the cost of installation and/or commissioning and this is delayed for a reason other than our fault any additional work caused by the delay shall be charged to and paid for by you in addition to the Contract Price.
- 10.2 Site visits for performance of the Services will take place at the intervals specified in our quotation and we will give you prior notice of each visit.
- 10.3 In addition to the cost of the Service as specified in the quotation, extra charges will be made for:
- 10.3.1 any materials used during the site visit;
 - 10.3.2 any Services being performed at your request outside normal working hours on a Business Day; and
 - 10.3.3 where applicable and agreed in advance with you, hotel accommodation.
- 10.4 On satisfactory completion of each maintenance visit our authorised service engineer will provide for signature a Maintenance Schedule and Report which you will ensure is signed by your duly authorised representative.
- 10.5 Any maintenance work to be carried out in performance of the Services shall be in accordance with our specifications.
- 10.6 To allow us to perform our obligations under this Contract, you will provide to us and will make sure that any other third party in control of the site where Services are to be performed provides (where applicable):
- 10.6.1 sufficient and suitable access to any site at which Services are to be performed;
 - 10.6.2 a cleared, prepared, and safe site which complies with all applicable statutory or other regulations and codes of practice; and
 - 10.6.3 all necessary information, including but not being limited to any relevant health and safety policies applicable to any of our personnel when carrying out the Services.
- 10.7 You will indemnify us for any Liability incurred by us as a result of you (or any applicable third party) not doing any of the things set out in Clause 10.6.

11 Passing of Risk

- 11.1 Risk of damage to or loss of the Goods shall pass to you in accordance with the relevant provision of the Incoterms. For the avoidance of doubt and unless agreed with you otherwise when the Contract is formed, this shall be on an Ex Works basis as detailed in clause 8.1

12 Title

- 12.1 Notwithstanding delivery in accordance with Clause 8 and the passing of risk in the Goods or any other provision of these Conditions, the property and ownership of the Goods shall not pass to you until we have received in cash or cleared funds

payment in full for the Goods and the Services and/or all other goods and services agreed to be provided by us to you for which payment is due.

- 12.2 Until such time that title to the Goods passes to you, you shall:
- 12.2.1 hold the Goods as our fiduciary agent and as our bailee;
 - 12.2.2 store the Goods separately from all other goods held by you so that they remain readily and clearly identifiable as our property;
 - 12.2.3 not remove, deface or obscure any identifying mark or packaging on or relating to the Goods;
 - 12.2.4 properly store the Goods and maintain the Goods in satisfactory condition and keep them insured against all risks for their full price from the date of delivery;
 - 12.2.5 notify us immediately if you become subject to any of the events listed in clause 14.1.4; and
 - 12.2.6 give us such information relating to the Goods as we may require from time to time, and
 - 12.2.7 hold any insurance proceeds on trust for us and account to us for the insurance proceeds.
- 12.3 You shall not be entitled to pledge or in any way charge by way of security for any indebtedness any of the Goods which remain our property but if you do so, all monies owing by you to us shall (without prejudice to any other right or remedy) forthwith become due and payable. .
- 12.4 Subject to clause 12.5, you may resell or use the Goods in the ordinary course of business (but not otherwise) before we receive payment for the Goods. However, if you resell the Goods before that time:
- 12.4.1 you do so as principal and not as our agent; and
 - 12.4.2 title to the Goods shall pass from us to you immediately before the time at which resale by you occurs.
- 12.5 At any time before title to the Goods passes to you, we may:
- 12.5.1 by notice in writing, terminate your right under 12.4 to resell the Goods or use them in the ordinary course of its business; and
 - 12.5.2 require you to deliver up all Goods in your possession that have not been resold, or irrevocably incorporated into another product and if you fails to do so promptly, we can enter any premises of you or of any third party where the Goods are stored in order to recover them.

13 Standard Warranty – All customers

- 13.1 Subject to Clauses 13.2 and 14 below, we warrant to you (the “**Warranty**”) that the Goods (excluding consumable items) and/or Services will be free from material defects in design, materials and/or workmanship for a period of 12 months from:-
- 13.1.1 in the case of Services, the date of completion of the performance of the Services; and/or
 - 13.1.2 in the case of Goods, the date of delivery of the Goods to you,
- (each referred to as the “**Warranty Period**”).
- 13.2 Subject to Clause 14 below, we shall have no Liability under the Warranty in respect of:
- 13.2.1 any defects in the Goods and/or Services arising from or due to our compliance with any instructions, drawings, design and/or Specification supplied by you;
 - 13.2.2 any defects in the Goods and/or Services arising from or due to the incorporation, exchange and/or use of any materials and/or components supplied by you into the Goods and/or Services;
 - 13.2.3 any defects in the Goods and/or Services arising from or due to the alteration by you or a third party without our prior written approval of the settings of the equipment control system (save controls designed for customers use);
 - 13.2.4 any faults arising after risk in the Goods has passed to you which are caused by any subsequent mechanical, chemical, electrolytic and/or other damage which is not due to a defect in the Goods and/or Services as appropriate;
 - 13.2.5 any faults arising after risk in the Goods has passed to you which are caused by a failure to store the Goods appropriately or otherwise than in accordance with any instructions or guidance issued by us at or prior to their delivery;
 - 13.2.6 any faults and/or defects caused by fair wear and tear, wilful damage, abnormal working conditions, failure to follow our operating, maintenance and installation instructions, misuse, alteration, modification and/or repair of the Goods and/or Services without our prior written approval and/or improper maintenance or negligence on your part and/or by a third party; and

13.2.7 any Goods and/or Services where we have stated to you prior to your Order in respect thereof or our acceptance of that Order, will not carry the Warranty.

13.2.8 where you makes further use of such Goods after giving notice of the defect in accordance with clause 13.6;

13.3 If any Goods and/or Services prove to be defective and are covered by the Warranty, we may at our sole option either repair or replace such Goods or reperform such Services. The repair and/or replacement and/or re-performance of the defective Goods and/or Services shall be your sole remedy in respect of claims under the Warranty. For non-UK customers, we will provide replacement parts in exchange for any that have become genuinely faulty during the Warranty Period. We accept no liability for any labour charges for non-UK customers during the Warranty Period. For small and/or relatively inexpensive* parts, replacements will generally be sent by express courier service. If we do not require the original faulty parts to be returned to us in exchange, we will specify this. For large and/or relatively expensive* parts, we reserve the right to have these returned to our factory in the UK for repair. The cost of returning any parts to us will only be reimbursed if we have agreed to this in writing, in advance. We will not reimburse any customer incurred costs, unless these have been authorised by us in writing, in advance.

*Note: we will determine and apply these definitions on a case by case basis.

13.4 Any Services provided by us which do not carry the Warranty will be charged at our current charging rates for such Services.

13.5 To enable us to assess whether the alleged defect in Goods and/or Services are within the scope of the Warranty given by us, you shall (at our request) either allow us access to your premises to enable us to view the defective Goods and/or Services and/or send the defective Goods or parts of the Goods to us for inspection. Any Goods sent to us for inspection shall be at your own cost and risk. If you are required to send the defective Goods or parts of the Goods to us for inspection and the defect is within the scope of the Warranty, we shall refund the costs reasonably incurred by you in delivering the defective Goods to us.

13.6 We shall have no Liability to you under the Warranty unless any defect is notified to us within 14 Business Days of the defect becoming apparent or suspected or when it should reasonably have become apparent to or suspected by you.

13.7 The Warranty above will not apply if you have not paid in full for the relevant Goods and/or Services on the due date for payment.

14 Liability

14.1 Our Liability for defective Goods and/or Services is limited as set out in Clause 12 and this Clause 13.

14.2 We shall have no Liability to you for any:-

14.2.1 loss of profits and/or damage to goodwill;

14.2.2 pure economic and/or other similar losses;

14.2.3 special damages;

14.2.4 aggravated, punitive and/or exemplary damages;

14.2.5 consequential losses and/or indirect losses;

14.2.6 loss and/or corruption of data; and/or

14.2.7 business interruption, loss of business, loss of contracts, loss of opportunity and/or loss of production.

14.3 Our total Liability to you for acts and/or omissions in connection with these Conditions in any relevant 12 month period shall not exceed £2,000,000.

14.4 The limitations and exclusions in these Conditions shall be deemed to be repeated and apply as a separate provision for each of:

14.4.1 Liability in contract (including fundamental breach);

14.4.2 Liability in tort (including negligence);

14.4.3 Liability for breach of statutory duty; and

14.4.4 Liability for breach of Common Law and/or under any other legal basis;

except that the limitation in Clause 14.3 above placing a financial cap on our Liability shall apply once in respect of all of the said types of Liability.

14.5 Nothing in this Contract shall exclude or limit our Liability for:

14.5.1 death or personal injury due to our negligence; or

14.5.2 any Liability which results from our fraud;

14.5.3 breach of the terms implied by section 12 of the Sale of Goods Act 1979;

14.5.4 defective products under the Consumer Protection Act 1987; or

14.5.5 any other Liability which we are not permitted to exclude or limit as a matter of law.

14.6 All warranties, terms, conditions and duties implied by law relating to fitness, quality or adequacy are excluded to the fullest extent permitted by law.

15 Termination

15.1 If you:-

15.1.1 fail to make any payment to us when due;

15.1.2 breach any of these Conditions (and, if the breach is capable of being put right you have not put it right within 10 Business Days of receiving a notice from us asking you to put it right);

15.1.3 persistently breach any one or more terms of these Conditions;

15.1.4 stop or threaten to stop carrying on business, are declared or become insolvent or bankrupt, have a moratorium declared in respect of any of your indebtedness, enter into administration, receivership, administrative receivership or liquidation or threaten to do any of these things, take or suffer any similar action in any jurisdiction or any step is taken (including, without limitation, the making of an application or the giving of any notice) by you or by any other person in respect of any of these circumstances;

15.1.5 appear to us to be financially unable to meet your obligations under the Contract; and/or

15.1.6 appear reasonably to us to be about to suffer any of the above events;

then we may, without prejudice to any other remedies, exercise any or all of the rights set out in Clause 15.2 below.

15.2 If any of the events set out in Clause 15.1 happen to you, then, without limiting any other right or remedy we may have:-

15.2.1 we may enter, without prior notice, any of your premises (or premises of third parties with their consent) where Goods owned by us may be and repossess and dispose of or sell any Goods found which are owned by us so as to discharge any sums due to us under the Contract or any other agreement we have with you;

15.2.2 you will automatically no longer be entitled to re-sell, use or part with the possession of any Goods owned by us until you have paid in full all sums due to us under this Contract or any other agreement you have with us unless we give our express written agreement to such use and/or disposal of the Goods;

15.2.3 we may withhold delivery of any undelivered Goods and stop any Goods in transit;

15.2.4 we may withhold the performance of any Services and cease any Services in progress;

15.2.5 we may cancel, terminate and/or suspend without Liability to you any Contract with you; and/or

15.2.6 all monies owed by you to us shall become immediately due and payable.

15.3 Termination of the Contract, however arising, shall not affect any of the parties' rights and remedies that have accrued as at termination. Clauses which expressly or by implication survive termination of the Contract shall continue in full force and effect.

16 Waste Electrical & Electronic Equipment (WEEE)

16.1 You shall exclusively finance the collection and delivery of waste electrical and electronic equipment (WEEE) to us or Technowaste Ltd, as required by the UK WEEE Regulations 2006 SI 3289.

16.2 This clause applies to all new electrical and electronic equipment (EEE) put on the UK market by us after 13 August 2005 (known as new WEEE), as well as all EEE put on the UK market before 13 August 2005 (known as historic WEEE) which becomes waste as a result of a purchase of new EEE from us after August 2005.

16.3 If you resell the EEE to a third party, you will ensure that this clause in its entirety is included in the contractual arrangements governing the sale to the third party. You agree to indemnify and keep indemnified and hold harmless us and B2BWEEE-Scheme from and against all costs and expenses which we or B2BWEEE-Scheme incurs or suffers in the UK as a result of a direct or indirect breach or negligent performance or failure in performance by you of your obligations in this clause.

17 Assignment and subcontracting

17.1 We may at any time assign, transfer, charge, subcontract or deal in any other manner with all or any of our rights or obligations under the Contract.

17.2 You may not assign, transfer, charge, subcontract or deal in any other manner with all or any of your rights or obligations under the Contract without our prior written consent.

18 Notices

18.1 Any notice or other communication given to a party under or in connection with the Contract shall be in writing, addressed to that party at its registered office (if it is a company) or its principal place of business (in any other case) or such other address as

that party may have specified to the other party in writing in accordance with this clause, and shall be delivered personally, sent by pre-paid first class post, recorded delivery, commercial courier, fax or e-mail.

18.2 A notice or other communication shall be deemed to have been received: if delivered personally, when left at the address referred to in clause 18.1; if sent by pre-paid first class post or recorded delivery, at 9.00 am on the second Business Day after posting; if delivered by commercial courier, on the date and at the time that the courier's delivery receipt is signed; or, if sent by fax or e-mail, one Business Day after transmission.

18.3 The provisions of this clause shall not apply to the service of any proceedings or other documents in any legal action.

19 Severance

19.1 If any court or competent authority finds that any provision of the Contract (or part of any provision) is invalid, illegal or unenforceable, that provision or part-provision shall, to the extent required, be deemed to be deleted, and the validity and enforceability of the other provisions of the Contract shall not be affected.

19.2 If any invalid, unenforceable or illegal provision of the Contract would be valid, enforceable and legal if some part of it were deleted, the provision shall apply with the minimum modification necessary to make it legal, valid and enforceable.

20 General

20.1 Neither party shall use and/or disclose any confidential information which is acquired by it about the other party's business and/or given by one party to the other party and/or generated by either party from the other party's confidential information except in the proper performance of this Contract.

20.2 You agree to indemnify us and keep us indemnified against any and all Liability and legal costs on a full indemnity basis suffered and/or incurred us and arising from or due to any breach of contract, any tortious act and/or omission and/or any breach of statutory duty by you.

20.3 A waiver of any right or remedy under the Contract is only effective if given in writing and shall not be deemed a waiver of any subsequent breach or default. No failure or delay by a party to exercise any right or remedy provided under the Contract or by law shall constitute a waiver of that or any other right or remedy, nor shall it preclude or restrict the further exercise of that or any other right or remedy. No single or partial exercise of such right or remedy shall preclude or restrict the further exercise of that or any other right or remedy. The invalidity, illegality or unenforceability of any of the provisions of this Contract shall not affect the validity, legality or enforceability of the remaining provisions of this Contract.

20.4 None of the terms and conditions of this Contract shall be enforceable by any person who is not a party to it.

20.5 The Contract, and any dispute or claim arising out of or in connection with it or its subject matter or formation (including non-contractual disputes or claims), shall be governed by, and construed in accordance with, English law, and the parties irrevocably submit to the exclusive jurisdiction of the courts of England and Wales.